

Zumbach

SWISS PRIME MEASURING SINCE 1957

In-line Monitoring & Control Equipment



Wire • Cable • Plastics • Rubber • Metal • Steel • Glass

ZUMBACH Electronics was founded in 1957 in Orpund, Switzerland, where it is still headquartered. Here and in the USA, we have established our centres for research, development, and manufacturing.

The goal of the ZUMBACH group is to offer the industry the most complete programme of measuring and monitoring instruments of the highest quality and technology. Worldwide support by competent advisors and reliable service is provided by 12 ZUMBACH owned enterprises and by over 40 agencies.



Headquarters in Orpund, Switzerland, Facility 1



North American Headquarters in Mount Kisco NY, USA

ZUMBACH subsidiaries in:



Italy



France



Spain



India



Germany



Great Britain



Taiwan



China

Telecom Cables
Extrusion
Singles
Jackets

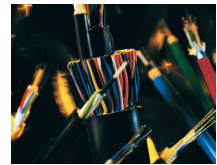

Power Cables
Extrusion
CV Lines
Rewinding



Fibre Optic Cables
Drawing
Buffering
Jacket Extrusion

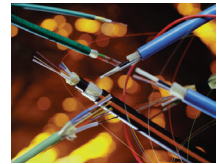

Wire
Wire Drawing
Wire Rod

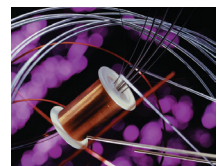

Plastic
Extrusion
Pipes
Profiles



Rubber
Extrusion
Hoses
Profiles



Non-Ferrous Metals

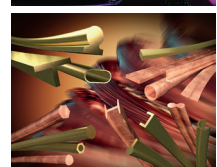

Steel / Metal – COLD
Bar, Rod
Pipes
Profiles



Steel / Metal – HOT
Bar, Wire Rod
Pipes
Profiles



Certified Quality

In addition to conforming to ISO 9001:2015, Zumbach's quality standards guarantee a highly precise, robust and reliable product. The goal of the ZUMBACH group is to offer industry the most complete line of measuring and monitoring instruments of the highest quality and technology. Worldwide support by competent advisors and reliable service is provided by 12 ZUMBACH owned enterprises and by over 40 agencies, we are committed to Total Customer Satisfaction.



ISO 9001:2015

Diameter / Ovality / Shape ODAC® Laser Gauges	4	5
Diameter / Ovality MSD – Linear Sensor Technology & Multiple Light Sources	6	7
Width / Height / Length / Profile / Shape ODAC® / DVW / DVO / PROFILEMASTER®	8	9
Wall Thickness / Concentricity / Diameter UMAC® / UMAC® CI / WALLMASTER	10	11
Concentricity/Eccentricity + Diameter ODEX®	12	13
Cross Section Measurement (X-Ray Technology) RAYEX® D XT / RAYEX® S	14	15
Capacitance Measurement / Fast Fourier Transform CAPAC® / FFT/SRL	16	17
Lumps/Neck-Downs / Surface Defects KW Fault Detectors / SIMAC®	18	19
Dielectric Testing / Spark Test Spark Tester, AST H, AST L, DST / CALIBRATOR SP	20	21
Conductor Preheating / Temperature Control ZUMBACH PREHEATER, AUTAC 300	22	23
Data Processing, Display, Control / Interfacing USYS Software	24	25
Process Control Systems for Multiple Sensors LSV – Laser Surface Velocimeters JACKET-/CELL-/WALL-/ODEX-/RAYEX-/BARMASTER® Speed and Length Measurement	26	27
For Hot Rolling and Processes in Harsh Environments ODAC® / STEELMASTER	28	29
Cold Steel and Metal Industry and Various Applications ODAC® / USYS SYSTEMS / DIAROND / BENDCHECK	30	31
Worldwide Sales and Service Network Addresses: The ZUMBACH Group / Representatives	32	

ODAC® Laser Gauges

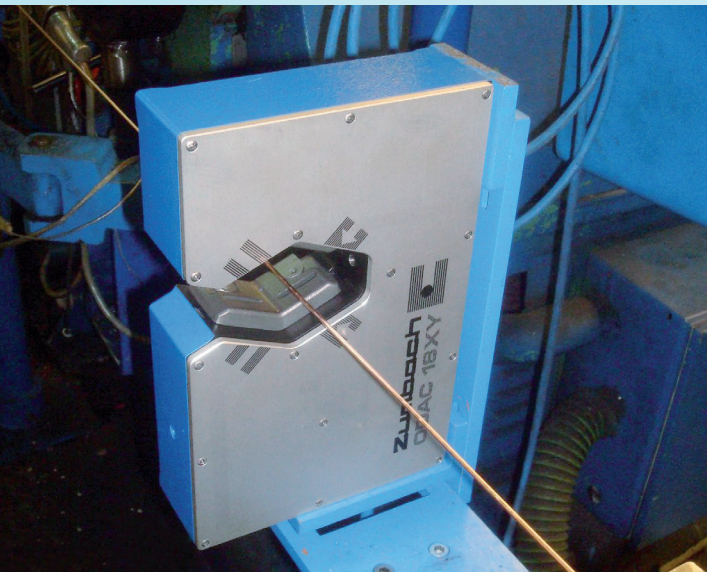

Over 90'000 ODAC® measuring heads have been in use successfully for over 60 years. From international conglomerates to the small manufacturing company, ODAC® instruments are being used in multiple industries, contributing to their success. The ODAC® brand does not only represent non-contact dimensional measurement, but also unusual insensitivity to dirt, the highest precision, and a compact design.

Important Features

- Very robust, lasting design
- Extremely insensitive to dirt
- Highly developed optics and scanning
- Highest accuracy and permanent calibration

Your Advantage

- Seamless quality control
- Short payback period
- Easily integrated anywhere
- Reliable operation even under rough conditions

Compact Intelligence

New generation of laser heads with high scanning frequency and versions for serial communication, Profibus DP, Profinet IO, Ethernet TCP/IP or EtherNet/IP make direct communication easy. Optional local display, analog interface and integrated web server.

VISU-Touch

This universal 7" touchscreen is powered by PoE (Power over Ethernet) and thus enables the display of the integrated web interface of the connected ZUMBACH device.

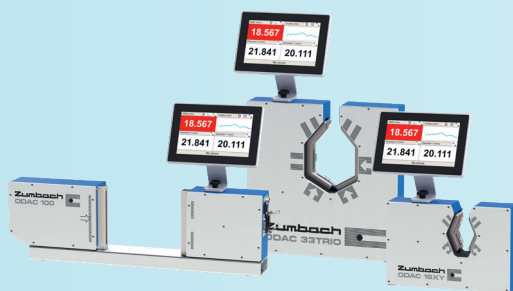

Typical Gauge Types



ODAC single axis, compact, modular, with or without rail



ODAC single axis, as components



ODAC 2 axis



ODAC 3 axis

ODAC® Measuring Heads in Operation

ODAC® systems are used for products in most any industries, like Wire & Cable, Plastics, Rubber, Steel and Metal.

Typical Solutions

- Diameter and ovality measurement
- Position measurement
- Depth and height measurement
- Multiple measurement
- Lump detector function (surface inspection)
- Hot and cold measurement
- Measurement of transparent products

Typical Products

- Cable and wire of any kind
- Singles, sector conductors, profiles
- Fiber optics, compound fibers
- Pipe, tubing, hose
- Steel, copper, aluminium rod

3 Axis Laser Measurement – The Solution for Accurate Diameter and Ovality Measurement

Diameter Scanner and Flaw Detector in One Unit

- 9000 measurements per second (FF version)
- 3 synchronized measurement axes on 1 single plane
- Single scan monitoring – up to 9000 scans/s
- Reliable detection of the ovality
- Yields highly accurate mean value, regardless of the orientation of the product ovality
- Integrated fault detector offers 3 times higher detection certainty and sensitivity than 2 axis models
- Computes accurate values of circumference and cross section (important for fittings of tubes and hoses)

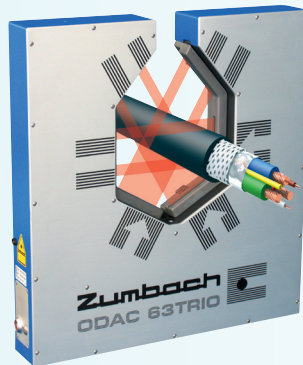

Comparison of 3 and 2 axis measurement: Orientation of the object

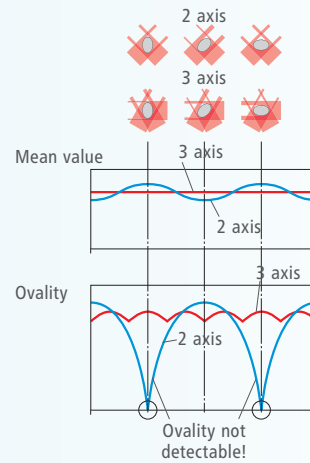

Possible Measuring Modes

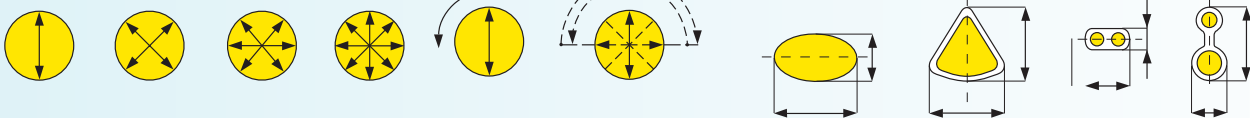

Possible Configurations for

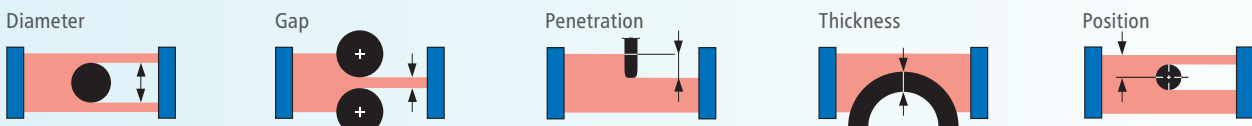

General Data

Measuring principle	High-tech laser scanning
Scan rate	240...3000/s
Laser	Laser diode red, class II
Measurable materials	Any material, opaque or transparent
Max. speed	Unlimited
Temperature range	Operating: 0...45 °C (-32...113 °F) Transport storage: -20...50 °C (-4...122 °F)

Key Data

Diameter range	0.012 ... 500 mm (.0005 ... 20 in.)*
Resolution	1 µm (.000039 in.)
Repeatability	down to 0.05 µm (.00002 in.)

*Larger diameters on request

MSD – Linear Sensor Technology & Multiple Light Source

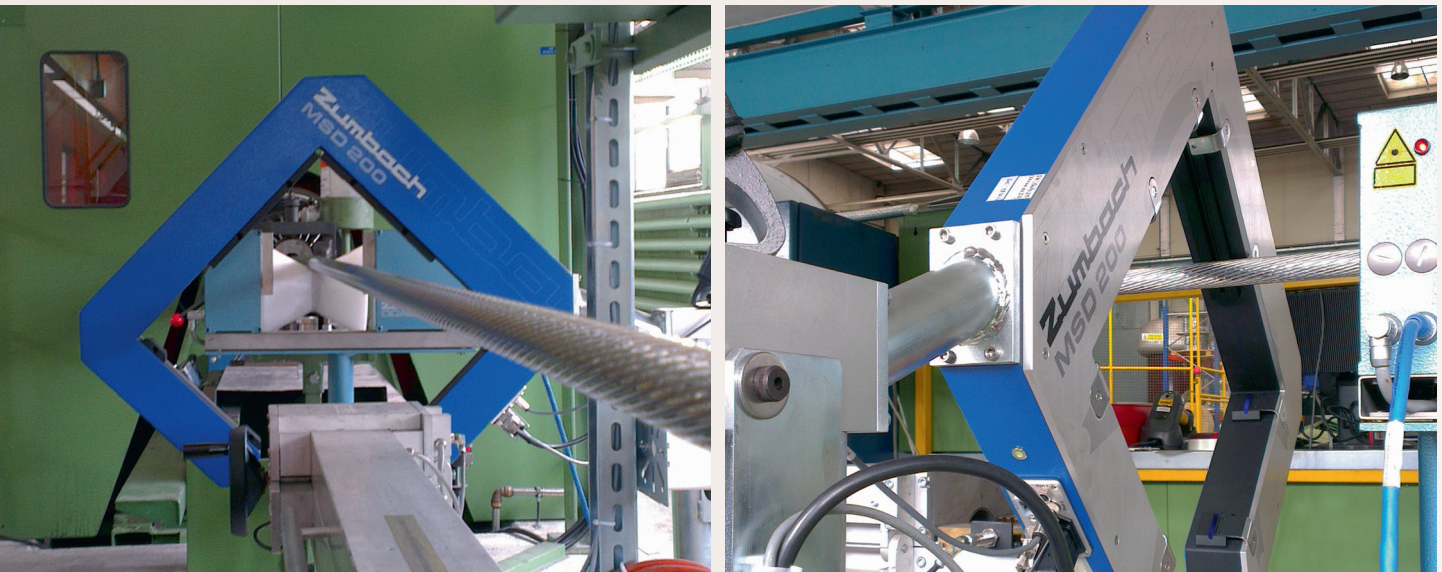

With the MSD Diameter Gauges, ZUMBACH introduces a new series of measuring heads for on-line diameter and ovality measurement and control. This new line complements the high-precision laser diameter measuring heads of the ODAC[®] series. The **MSD models** achieve their ideal efficiency in terms of price and performance specifically for applications in the cable and plastics industry. The experience of 60 years with on-line and off-line measurement and control technology has led to a product characterised by the most current and sophisticated technology and functionality as well as by the well-known ZUMBACH accuracy and reliability. Thanks to our new MSD* technology (pat. pend.) it was possible to build very compact yet accurate measuring heads.

* = Multi-Source-Device

Special Features

- Cost-effective measurement solutions thanks to an ideal ratio between technology, performance and application
- Intelligent and innovative design: With special floor stands, the measuring heads can be swivelled upwards, out of the production line
- LEDs of different colours provide the lighting of the axes. There is then no interference between measurement axes, even with simultaneous measurement – and not even with reflective products
- Built-in external light filters to prevent ambient light affecting the measurement
- Active redundant measurement by means of up to 8 LED sources
- KW function (detection of surface defects)

Options / Accessories

A comprehensive amount of options and accessories is available for the complete range of MSD gauges. It is therefore possible to offer the ideal solution for any application.

- Vertically adjustable stands
- Local display
- Air curtains
- Accessories for the length detection
- Additional analogue interface box
- Various cable lengths

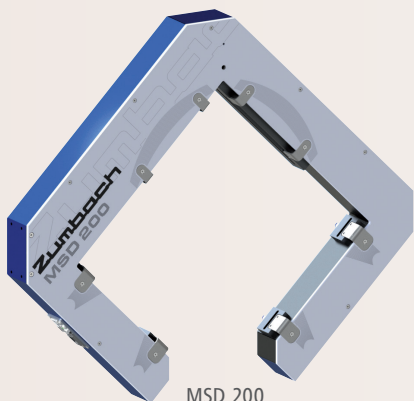

MSD 200

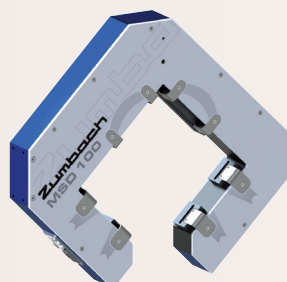

MSD 100



MSD 50

Application

The MSD models are suitable everywhere and can be used in all cable manufacturing lines for measuring all kinds of wires and cables. They are indispensable tools in tube and hose extrusion lines for measuring pressure, waste water, heating tubes, etc. as well as all kinds of hoses.

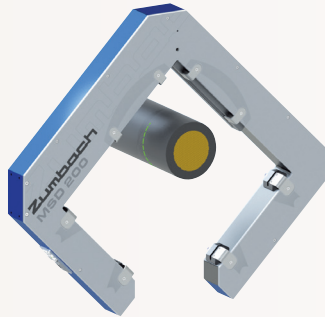

Ergonomic Design

By fitment of the optional floor stands, each measuring head model can be swivelled upwards. This allows for easier working access when needed in confined spaces and simple removal of the measuring head from the production line.

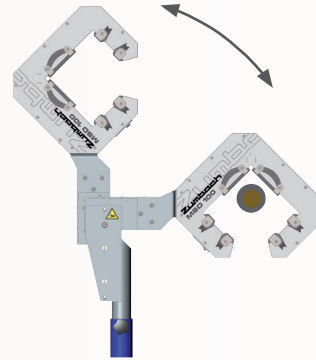

Measuring Principle

The measuring principle is based on the latest CMOS technology with several point-like LED's as light sources. The shadow of the object to be measured, originating from the various light sources, is projected on a line sensor. The line sensor calculates the position of the shadow, thus resulting in different measuring points. These points generate four fictitious shadow lines, which define a square enclosing the object to be measured.

MSD 50

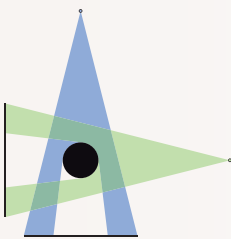

MSD 100 & MSD 200*

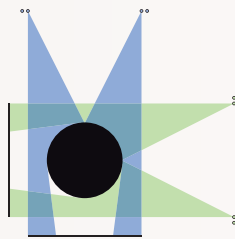

MSD 100 & MSD 200*

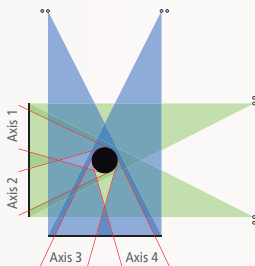

* Both figures only show the beam trajectory based on 4 light sources. Both the MSD 100 and MSD 200 models are equipped with 4 light source pairs.

Thanks to the new and unique ZUMBACH concept of up to 8 light sources for the models MSD 100 & MSD 200, multiple shadows on each axis can be evaluated (1 shadow = 1 axis). This allows a multi-axis measurement of smaller products (pat. pend.). Therefore the product must be arranged within the measurement field:

- For MSD 100: within \varnothing 20 mm (.8 in.)
- For MSD 200: within \varnothing 54 mm (2.1 in.)

The **VISU-Touch** is a universal 7" touch screen powered with PoE (Power over Ethernet) enables display of the integrated web interface of the connected ZUMBACH sensor device. Since the service interface does not support directly the PoE, the PoE injector, available as an accessory, must be inserted between the measuring head and the VISU-Touch. The VISU-Touch is supplied with a holder for fixing. Not for J versions.

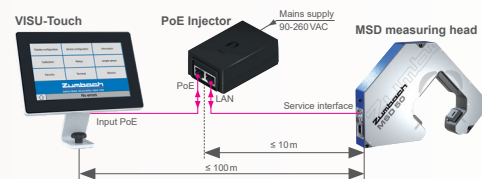

General Data

Model	MSD 50	MSD 100	MSD 200
Number of measuring axis	2	2 (4)	2 (4)
Number of LED sources	2	8	8
Measuring field M	\varnothing 50 mm (2 in.)	100 x 100 mm (4 x 4 in.)	200 x 200 mm (8 x 8 in.)
Min. object diameter	0.5 mm (.02 in.)	1 mm (.04 in.)	2 mm (.08 in.)

All models are available as version RS-232/-422/-485, Profibus DP, Ethernet TCP/IP, Profinet IO or EtherNet/IP available.

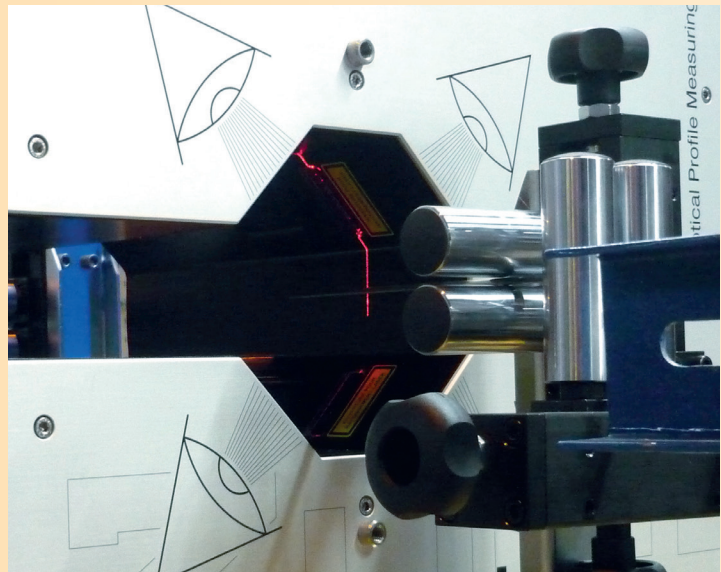

ODAC®-JK and -JP Versions with Modular Emitter and Receiver

Special optics and special signal evaluation make these versions suitable for measurement of width, height, depth, and profile. Emitter and receiver can be mounted at practically any distance in order to accommodate for the product. This approach is also used under extreme conditions, where considerable measuring distances are required due to heat radiation or dirt emission. By utilizing 2 measuring heads and synchronization techniques, even large diameters, lengths or widths can be measured with high accuracy.

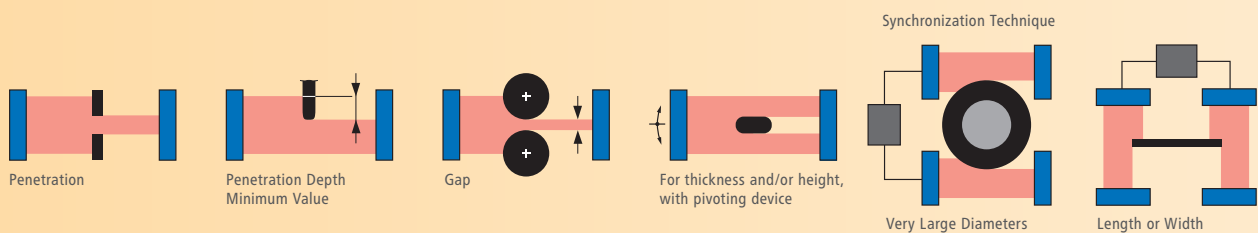
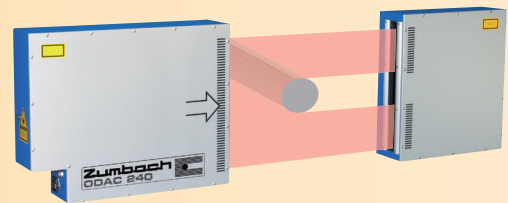

Pivoting Supports DVW / DVO

are mechanical oscillating devices for ODAC® measuring heads. In the adjusted angle of +/- 2.5° up to +/- 25° (depending about model DVW 1 or DVO 2), the device oscillates the measuring heads (mounted on a disc) continuously around the product. Thanks to its rugged design, the DVW units can be easily installed and operated in each production line without additional reinforcement elements. The universal design of the DVW enables the use of numerous ODAC® models, qualifying the device for a wide range of applications where precise measurement of height and width is required.

- Our proven USYS processors are at your disposal for further processing of the measurement data and display.

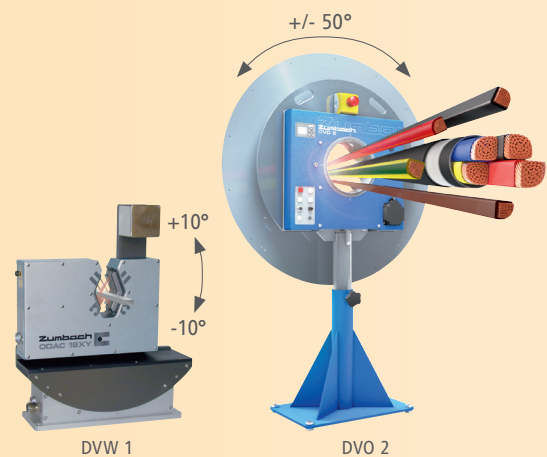



PROFILEMASTER® – Accurate In-line Profile Measurement Using Light-Section Principle and Machine Vision

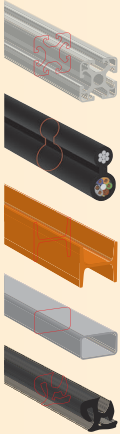

PROFILEMASTER® systems measure and monitor profiles and other non-round products during the production process. The complete cross-section is graphically displayed on the screen, based on a sophisticated image processor.

Main Data

Measuring field ¹⁾	Till 800 mm (31.5 in.)
Light source	Laser diode red, class 3R
Operating system	Windows®

¹⁾ Depending on the model and on the product geometry and position; bigger fields on request.

Measuring Principle

The measuring principle is based on 2D laser triangulation respectively light-sectioning technology. Four or more lasers illuminate the product surface and the associated matrix cameras capture the light contour from an oblique angle. A powerful and fast computer and the PROFILEMASTER software combine the captured segments into an orthogonal profile cross-section.

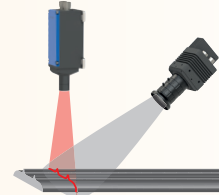

A PROFILEMASTER® System for Any Requirement

When designing the PROFILEMASTER® system, concentration was focused on the most suitable solution in terms of price / performance ratio for the application.

- Due to the modularity of the PROFILEMASTER® system this goal could be achieved.
- The combination of 4 to 8 laser / camera modules allows the measurement of virtually all shapes, achieving an optimal measurement result with the smallest possible number of laser / camera modules.

Benefits

- Increases the accuracy of your end product
- Improved process control
- Scrap reduction
- Savings on raw material and post processing costs
- Increased product quality = Higher customer satisfaction
- Quick and easy installation on existing production lines

PMM 130-4K/160-6K



Universal unit with angle adjustment. To support 4 or 6 laser/camera modules.

PMM 30/50/80



Compact and cost-effective version with 4 laser/camera modules.

Processor and display units



Compact

19" cabinet

SPS 200/400/550/800

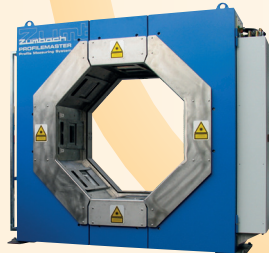

Fully protected version constructed with up to 8 laser / camera modules for harsh environments that are typical in the steel and metal industry. Especially suitable for billets, semi-finished products, H, I, U, L beams etc.
▶ 2kHz models now available.

SPS 80-S4



Fully protected version constructed with up to 8 laser / camera modules for harsh environments that are typical in the steel and metal industry. Especially suitable for rebar, H, I, U, L profiles etc.
▶ 2kHz models now available.

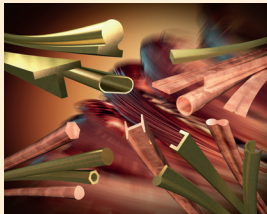

UMAC® • UMAC® CI • WALLMASTER

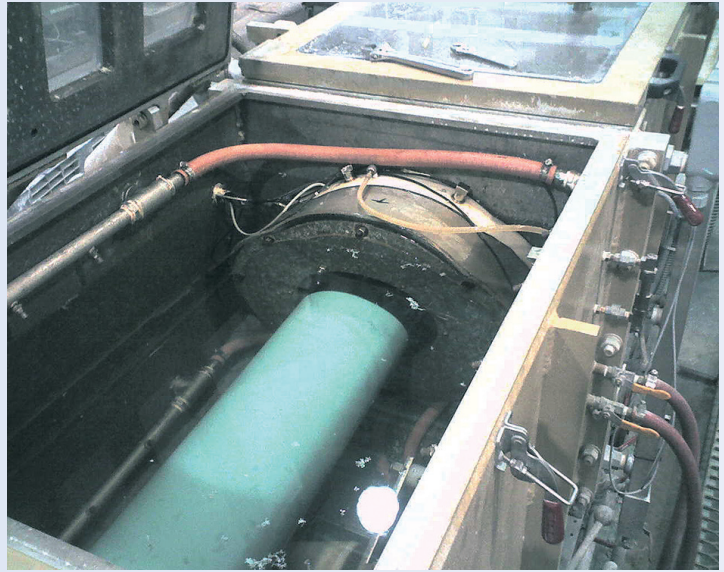
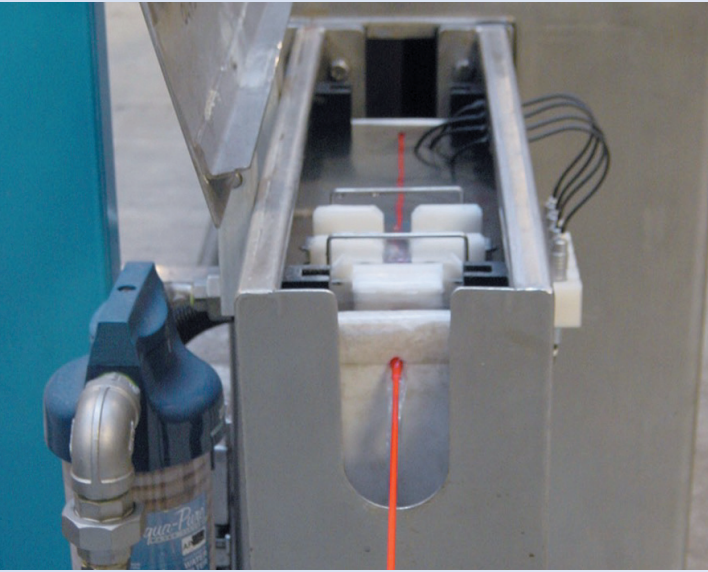

UMAC® represents a line of ultrasonics based systems for wall thickness measurement and control of pipe, hose, tubing and cables. Each system consists of a highly developed UMAC® processor, interrogating up to 8 transducers at high speed. WALLMASTER systems process data from several ODAC® measuring heads and a UMAC® wall thickness measuring system. Automatic control of wall thickness and/or diameter is easily possible. Calibration can be automated by means of the DIACAL options.

Measuring Solutions Made Possible with UMAC® WALLMASTER

- Diameters down to 0.3 mm (.01 in.)
- Wall thickness down to 0.08 mm (.003 in.)
- Multi-Layer up to 5 layers
- Medical tubes
- Plastic pipes up to 350 mm (13.8 in.)*
- Rubber hoses
- Jackets on CAT 5, 6 ... 8 data cable
- Loose tube and thin jackets in general
- Insulation and jackets on cables
- Coatings over metal cores
- Continuous control of cable, thanks to measurement directly at the extrusion die head

* Bigger diameters upon request

Wall Thickness and Concentricity Measurement

The UMAC® transducer holders record the wall thickness at several points of the product. The sophisticated WALLMASTER processors display easy-to-understand information of product geometry and thickness values.

Wall Thickness and/or Diameter Control

Pipe or tubing wall thickness or thickness of insulation or jackets of cable can automatically be controlled over the haul-off speed or the extruder rpm. Additional servo valves are available for automatic diameter control via the calibration vacuum or the support air.

UMAC® transducer holder versions

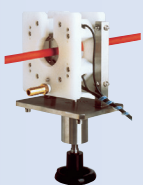

UMAC® A5/10/20



UMAC® RZ35/65

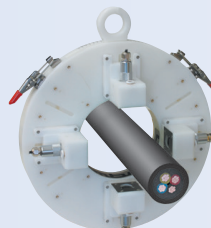

UMAC® Z50/100/180

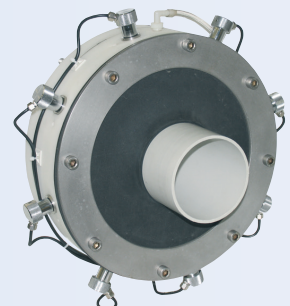

UMAC® R for pipe

Jacket Extrusion

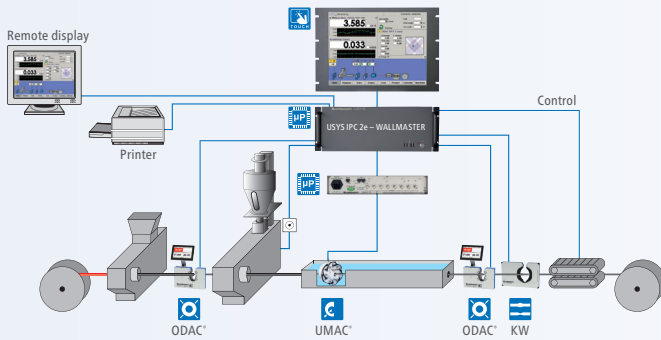

Tubing Extrusion

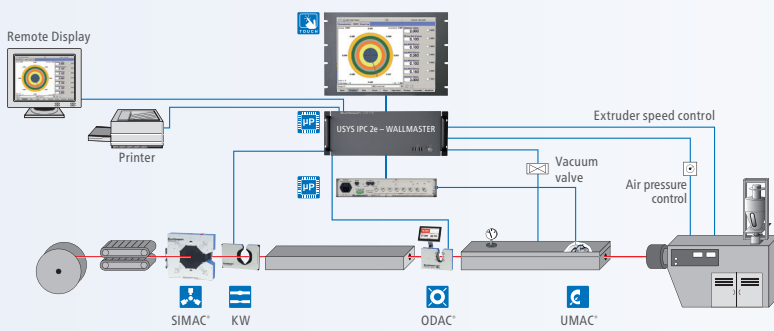

Pipe Extrusion

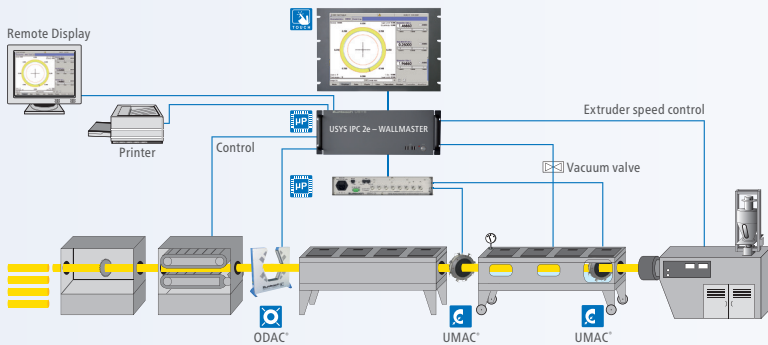

DIACAL 8000

For Compensation and Automatic Calibration of the Wall Thickness. DIACAL 8000 is a smart method for the simplified calibration. Compensation of any wall thickness value (layer) through the wall thickness measurement of 2 diameter sensors (D2-D1/2). Max. 4 compensation controllers can be configured.

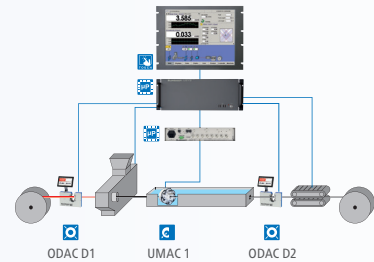

Advantages

- Precise wall thickness measurement of cable jackets
- Automatic calibration of the ultrasonic measurement using intelligent utilisation of the diameter measurement
- Economic solution because it employs the existing and essential diameter measuring instrument
- Optimises material consumption
- Generally improves the process

USYS ICP 1e/2e – Data Acquisition, Processing and Display Systems
Modular multi sensor processors for one and multi layer products.

Webserver

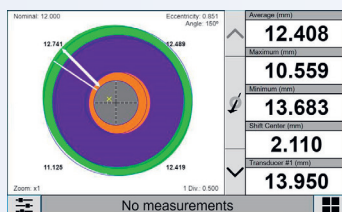

NEW! Now with integrated communication interface.

► For further specifications, please ask for the new UMAC CI prospectus



UMAC CI
High-tech measured value processors for ultrasonic wall thickness measurement.

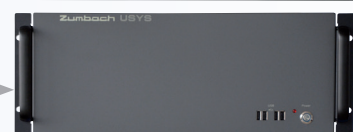
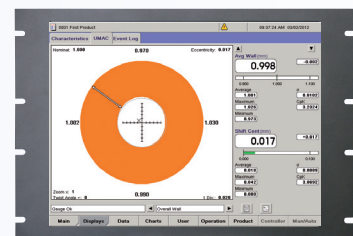

USYS IPC 1e / USYS IPC 2e with Display – 19" Touch-Screen
Multi sensor data acquisition and process control systems.



Magnetic/Optical Concentricity/Diameter Monitoring

For many years the inductive, rotating METREX® eccentricity gauges were considered the standard in the cable industry. Today, the high-tech ODEX® system is fast becoming today's standard. It features full non-contact measurement and monitoring of eccentricity/concentricity, minimum wall, diameter and ovality and offers high precision.

Your Benefits

- Material savings
- Increased production
- Better utilization of production lines
- Continuous process and quality monitoring
- Non-contact measurement and monitoring of outside diameter, wall thickness and ovality.



ODEX® is the ideal solution for:

- Data cables (LAN, cat. 5...8)
- Telephone cables
- Automotive cables
- Electronic wire
- Building wire
- Special cables
- Coax, mini-coax

VISU-Touch

This universal 7" touchscreen is powered by PoE (Power over Ethernet) and thus enables the display of the integrated web interface of the connected ZUMBACH device.





Concentricity / Eccentricity + Diameter + Ovality

The Patented ODEX® Concept

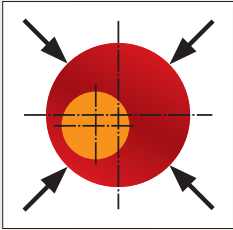

ODEX® 10 utilizes the latest technology in laser optics and magnetic measurement. It's fully digital (DSP), extremely fast, stable and compact. ODEX® 10 is a novel concept from ZUMBACH for very accurate and reliable monitoring of insulation diameter and conductor eccentricity/concentricity during extrusion or other insulating processes of ferrous and non-ferrous conductors. The ODEX® measures eccentricity, diameter and ovality within microns ($1\mu\text{m} = 0.001\text{mm}$ [0.0004 in.]). In applications of modern data cables cat. 5...8 and many other cable products, this often decides if the product passes or fails quality control requirements.

- High measuring frequency! 2400 simultaneous laser and magnetic measurements/s
- For outside diameters as small as 0.08 mm (.003 in.)
- As easy to operate as a diameter gauge
- Extremely compact – only 110 mm wide (4.3 in.)
- Flexible – works on ferrous and non-ferrous conductors
- True minimum wall measurement
- Flexible communication integration
 - Interface Service: Ethernet TCP/IP, RJ45 10/100 BaseT, galvanically isolated
 - Interface Host: RS-232/-422/-485, Profibus DP, Ethernet TCP/IP, Profinet IO or EtherNet IP
 - Interface J: For FFT analysis on USYS

Configurations for Any Budget

Integrated analog outputs, serial ports, and a modern bus system, Profibus DP, allow for any imaginable configuration.

Measuring Head Only

With built-in processor and bidirectional communication to host computer or PLC.

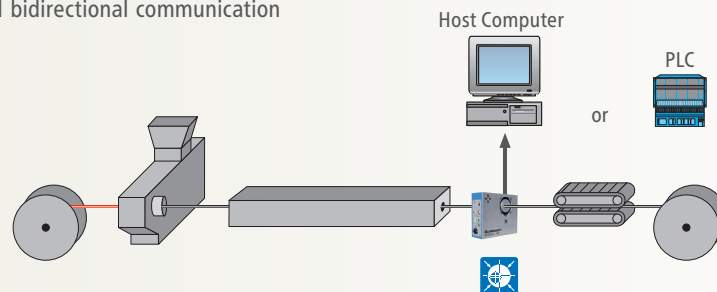

Complete System

ODEX® measuring system with USYS processor. Can be used together with other sensors (see also page 24/25). According to choice: – USYS 200 – USYS IPC 1e / 2e

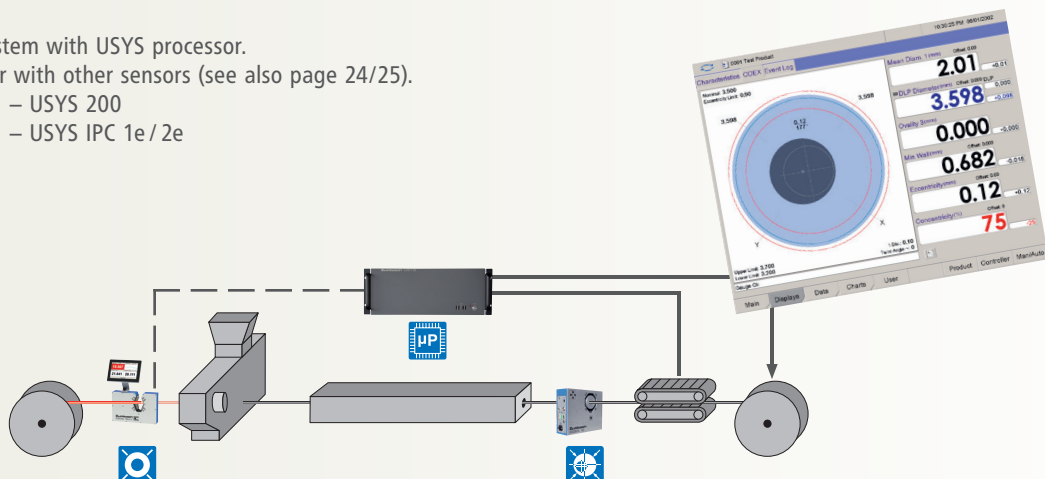

RAYEX® D XT / RAYEX® S

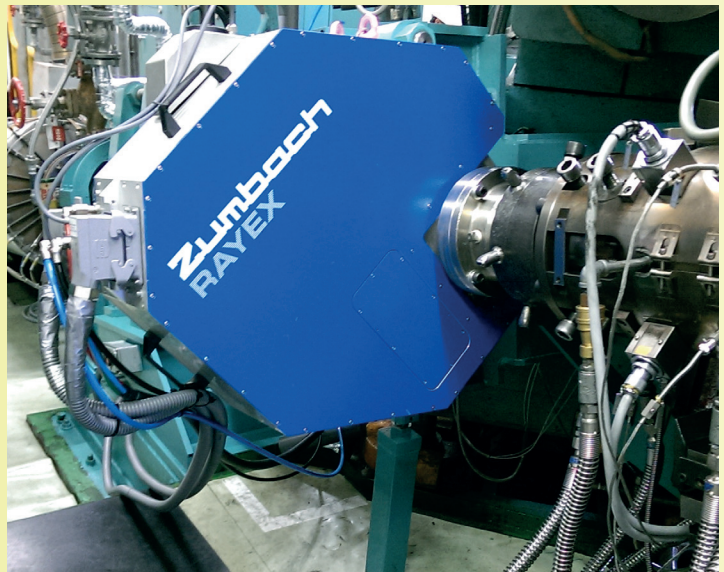

RAYEX® is a State-of-the-Art X-Ray Measuring and Control Systems for Wall Thickness (3 layers), Eccentricity, Diameter / Ovality

(Patents US 5 518 681, US 5 795 531 and CH 685 336 A5).

During the extrusion process, RAYEX® measures the wall thickness, eccentricity, diameter, and ovality of multi-layer cables with XLPE and EPR insulation, multi-layer pipes with foam core, composite pipes, and multi-layer hose. RAYEX® systems have been in use for years on various production lines and processes with great success:

- Steam – or steam/nitrogen lines
- Catenary lines
- Vertical lines
- Horizontal MDCV lines ("long die")
- In Silane, Sioplast / Monosil processes
- In foam core pipe extrusion

Safe, accurate and economic in any line and process:

- CV lines
 - CCV, VCV
 - MDCV
 - Steam CV
 - Rubber CV
- Silane for LV and MV
- Subsea cables

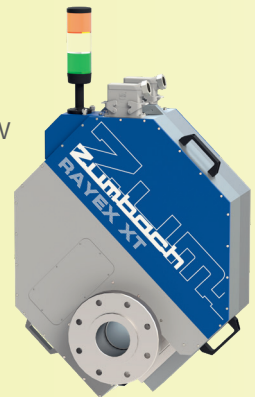

The measuring system RAYEX D XT is typically used on CCV, VCV or Silan extrusion lines. Individual implementation designs offers the best measuring results.

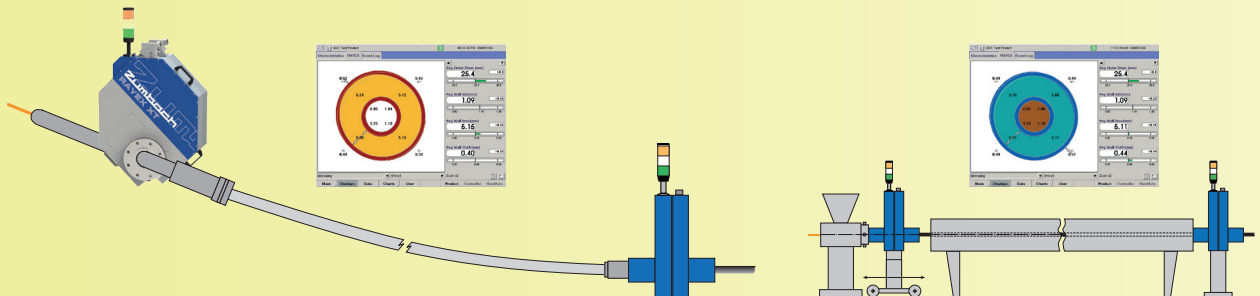

Customized measuring tube segments

Zumbach Electronic has wide experience and a high quality standard for the design and manufacture of customized tube segments for each particular applications.

- For nitrogen and/or steam CV lines
- For all relevant safety standards (TÜV etc.)
- Made of highest quality stainless steel.

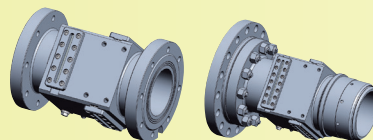

Typical designs of customized and delivered segments.



Cross-Section Measurement (X-ray Technology)

The new RAYEX S system combines modern X-Ray technology and easy operation in one unit. The high flexibility and convincing performance of RAYEX S are providing significant advantages:

- **Fast installation and commissioning**
- **Easy operation and product setting**
- **Longevity, especially of X-ray sources**
- **Easy maintenance and service**

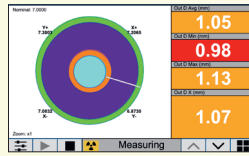

Easy and Reliable Measurement of Diameter, Ovality, Wall Thickness and Eccentricity for Products up to 100 mm (3.9 in.) Outer Diameter

Cables: Coax, CATV, Silane, Jackets

Tubing/Pipe: PVC, PE, PA, Composite Pipes, Automotive, etc.

Hoses: Rubber, Medical, Silicone, PTFE, etc.



- **High stability and accuracy**
 - Repeatability within 0.04 mm (.0023 in.)
 - No calibration needed
 - No need for material-specific adjustments
- **Simple concept and easy to use**
 - Display of four wall thickness and two diameter measuring points incl. resulting ovality
 - Two X-ray sources mounted 90° to each other
 - No moving parts
- **X-ray sources**
 - Extremely robust and stable
 - Easy to exchange, no realignment
 - Expected lifetime up to 4 years
 - No water cooling required
- **X-ray safety**
 - Comprehensive shielding concept
 - Minimal scatter, no lead necessary
 - Outside radiation level meets national and international standards
- **For all materials / combinations**
 - Plastics, foam, rubber, composites (metal/plastics), foamed structures
 - Up to four layers measurable
- **Embedded bus communication interface**

The RAYEX S is available with an embedded bus interface for integration into the customer's line control system.

 - User friendly setup of the product recipe
 - Readout of all measurement results possible
 - Ethernet and Profinet IO interfaces available
- **USYS processor and display unit**

The proven Zumbach processors for process monitoring, control and data acquisition.

 - Continuous display of measurement results
 - Recipe management
 - Monitoring of limit values
 - Statistics recording and protocolling
 - Line speed control
 - Compatible with other Zumbach devices

Measuring unit with embedded bus communication interface

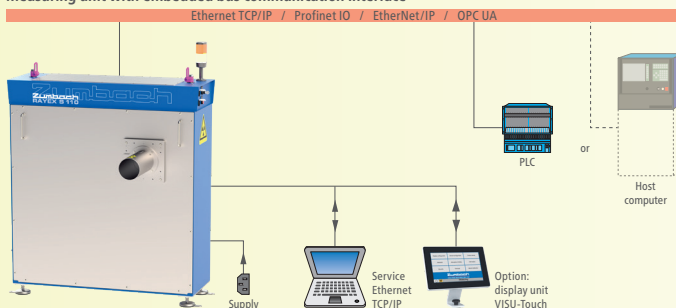

The design with embedded communication interface allows the higher-level system to configure and capture measurement results. The measuring algorithm itself is controlled by the RAYEX S and only requires the number of layers and the nominal wall thickness to be specified. All measurement results can be read and processed by the higher-level system. Available interfaces are: Profinet IO, Ethernet TCP/IP, EtherNet IP and OPC UA.

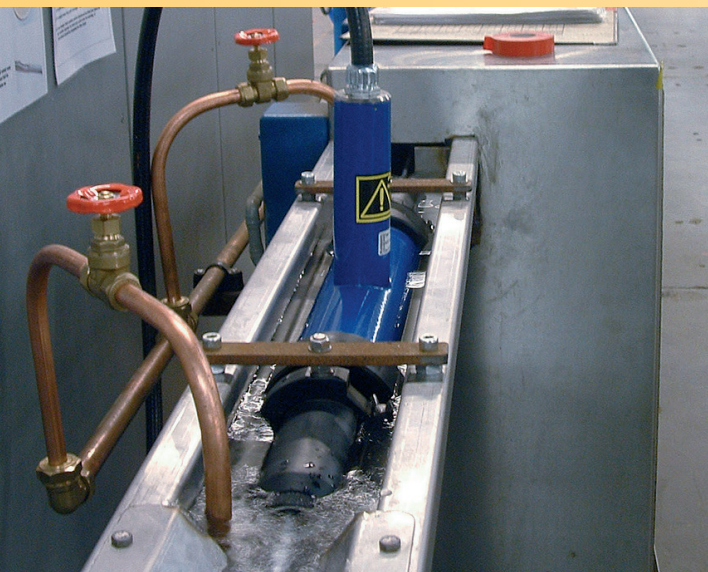

In-line Capacitance Measurement with CAPAC® Systems

The measurement is based on the unique and patented principle of the "active measuring tube". This system offers outstanding accuracy and stability. The measurement is not influenced by the water quality (pH value, etc.) or the line speed.

Important Features

- Precise continuous measurement of the capacitance of singles and cables
- "Pinhole" function. Detection of pores and tears in the insulation
- Direct connection of SRL/FFT Systems

Your Benefits

- Communication with host computers
- Statistical monitoring and documentation
- Distance between sensor and processor up to 200m (650 ft.)

Electronic Units



Main data

Measuring Range (selectable)	0...300 pF/m, 0...600 pF/m, 0...900 pF/m, 0...1800 pF/m 0...100 pF/ft, 0...200 pF/ft, 0...300 pF/ft, 0...600 pF/ft
Bandwidth analogue output	1...600 Hz (adjustable)
Ground potential analogue output	With IA*: free of potential Without IA*: earth potential
Accuracy	+/- 0.1 pF/m (+/- .03 pF/ft.), +/- 0.3%

* IA = Isolation Amplifier

Standard tubes with a measuring length of 50 mm (2 in.)

These measuring tubes are specially designed for the measurement of CAT type communication cables. These tubes feature a very high signal to noise ratio as well as a large band width. This is especially advantageous when capacitance variations must be monitored e.g. for FFT/SRL analysis.

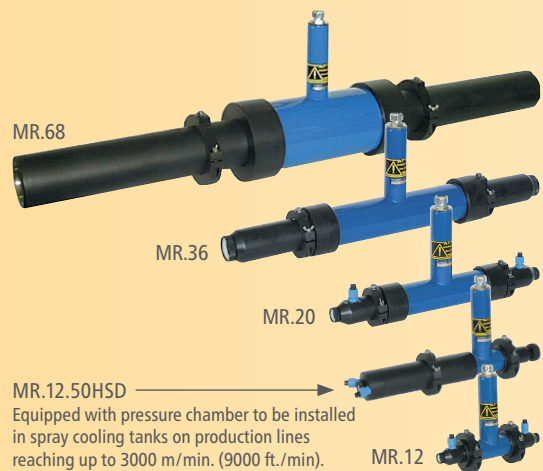

Ultra Short, Low Noise Measuring Tubes

For mini-coax, coax and LAN cables. Advantages with a single 10 mm (.39 in.) measuring segment:

- High length resolution with low noise level
- SRL prediction up to 6.5 GHz
- 600 Hz bandwidth of measuring system
- High absolute accuracy
- Compact and robust design

Systems Configurations

The basic system consists of a MR measuring tube and an electronic unit in water resistant compact housing, protected as per IP 65. The compact box offers the user all modern data ports for connection to processors and display systems from ZUMBACH or to host computers and to local area networks.

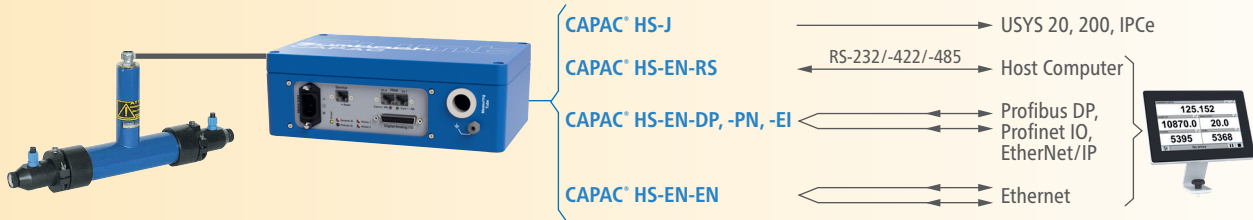

Data processing and display units from ZUMBACH (USYS 20 / 200, USYS-Touch, USYS IPC 1e/2e CELLMASTER) or customer systems, such as PLC's and Host computers.

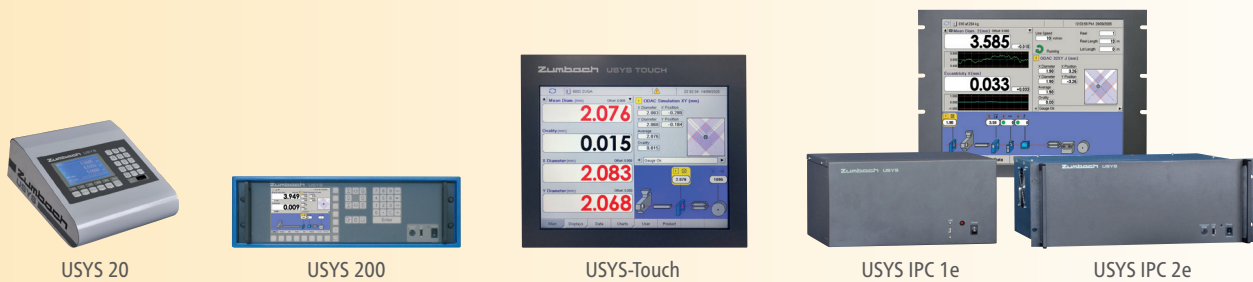

In-line Analysis (FFT) of Structural Return Loss (SRL)

This optional software allows the prediction of structural return loss, SRL, during manufacturing of the product. All standard systems are equipped with a very fast analog output, making short capacitance variations available. This signal is fed into a processor for fast "Fourier" analysis (Fast Fourier Transform, FFT) and the change of cable impedance is displayed on the screen in real time.

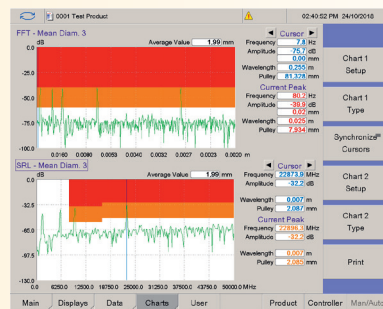

Applications

Data cable cat. 5, 6...8	Up to 1200 MHz at 2500 m/min. (820 ft/min.)
Coax, CATV Cable	Up to 6 GHz at 500 m/min. (164 ft/min.)

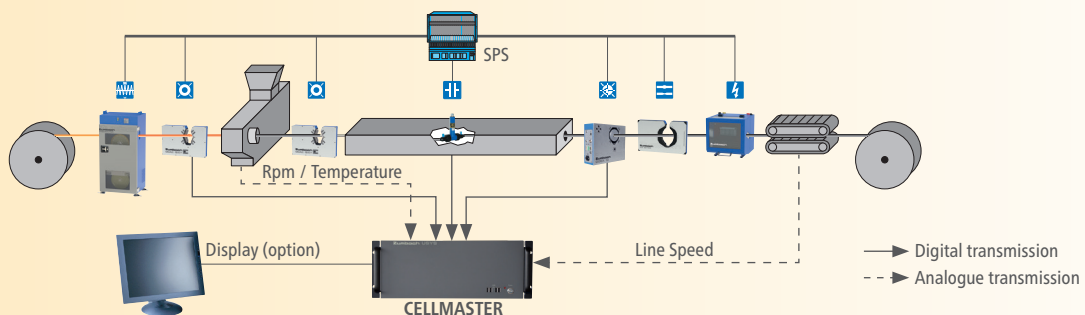

KW Fault Detectors • SIMAC®



Fault Detection, Surface Inspection



Your demands for a reliable and flawless detection of extrusion faults and surface defects are ever increasing. This applies to extrusion, jacketing, enamelling, drawing, and many other areas. For this reason, the use of optical fault detectors ("lump detectors") is very popular. These photometric detectors are able to detect small lumps, neck-downs, and other defects on wires, cable, tubing, etc., without being influenced by product parameters, line speed, vibration, etc.

Conventional Detectors

1 axis system

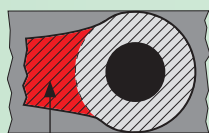

Theoretically a huge fault can remain undetected

2 axis system

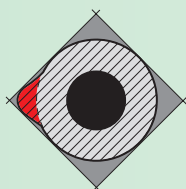

3 axis system

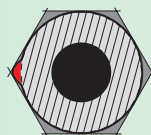

Significantly improved detection with the KW-TRIO principle

- 3 times higher detection reliability than conventional 2-axis systems
- Theoretically unlimited life expectancy
- Not sensitive to stray light
- Flexible mounting concept
- Integrated air curtains for cleanliness of windows

■ Biggest undetected fault

■ Blind zones

Surface Quality Inspection System



The SIMAC® is a modern surface inspection system for extruded products, like pipe, cable, and hose, where machine vision technology is used consistently. Mechanical design and software are the result of years of experience and refinement. The system takes into account the most diversified surfaces and colours, which exist in case of extrusion of plastic or rubber products. The SIMAC® system spots the smallest surface defects anywhere on the product, even at the periphery, with certainty.



Lumps/Neckdowns



Surface Defects

KW – Highest detection accuracy with Photometric Lump Detectors



KW 13/33TRIO

- 3-axis models with powerful micro processor and full digital signal processing DSP
- Unique measuring principle and complex optics solution provide the highest detection accuracy and ensure immunity to stray and intense light
- Very compact design

Main Data	KW 13TRIO	KW 33TRIO
Number of measuring axes	3	3
Measuring field	13 mm (.5 in.)	33 mm (1.3 in.)
Tolerance range setting	0.01...10 mm (.00044 in.)	0.025...30 mm (.001 ... 1.18 in.)
Tolerance range resolution	0.001 mm (.00004 in.)	0.001 mm (.00004 in.)
Minimum fault length	0.25 mm (.01 in.)	0.30 mm (.012 in.)
Smallest detectable fault (height)	0.01 mm (.0004 in.)	0.025 mm (.001 in.)



Operating and Display Unit VISU-Touch

The KW detectors are also available as stand alone devices. Thanks to a local operating and display unit, these versions can be fully operated and configured at the device.

- 7" touch screen to display values and messages
- Set point and tolerance inputs with colour variation for fast indication of tolerance violations
- Inbuilt terminal for extended device configuration/interrogation
- Can be used as local display or remote networked display

SIMAC® – Detection with Machine Vision System / CCD Camera

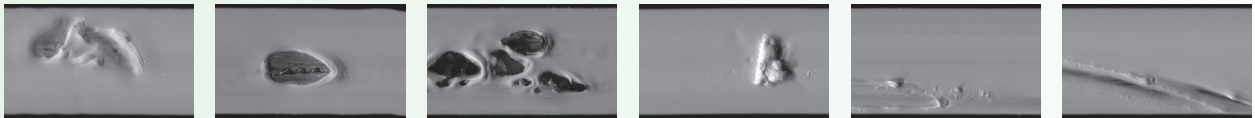

Applications where SIMAC® Inspection Pays for Itself Quickly

- Hot water pipes
- Composite pipes
- Gas pipes
- Automotive plastic tubing
- Automotive rubber hose
- Multi-layer pipe and hose
- "Off-shore" products
- High voltage cable
- Fibre optic cable

Important Features

- Easy operation (human machine interface)
- Recording of faults DIS_Digital Image Storage
- Fault classification
- Summary printout



Main Data	SIMAC 40	SIMAC 70	SIMAC 120
Product shapes	Round	Round	Round
Measuring field	ø 40 mm (1.57 in.)	ø 70 mm (2.76 in.)	ø 120 mm (4.72 in.)
Min. product dimension	2 mm (.078 in.)	14 mm (.55 in.)	30 mm (1.18 in.)
Max. product dimension	36 mm (1.42 in.)	63 mm (2.48 in.)	108 mm (4.25 in.)
Min. detectable defect size	0.1 mm (.0039 in.)	0.2 mm (.0079 in.)	0.4 mm (.016 in.)
Max. line speed	130 m/min	130 m/min	130 m/min

SPARK TESTER AST H, AST L, DST • CALIBRATOR SP

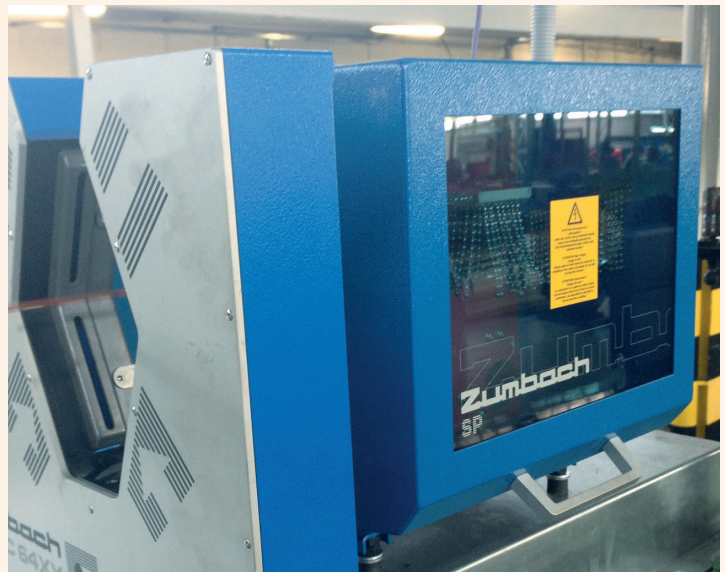

Dielectric testing with the spark-test method

In-line fault testing on single wires and cables during the extrusion or rewinding process has become standard procedure today. ZUMBACH Spark Testers can be used to test the most diverse range of cable products as per international standards, like IEC 62230, UL 1581, UL 2556 and other. Integrated ports allow communication for easy integration with quality control systems (e.g. USYS).

Important Features

- Robust, durable
- Accurate, repeatable
- In compliance with standards
- Selective
- Optimum operation
- Available in all sizes

Vital for Quality Assurance and ISO 9000

CALIBRATOR SP 40A

The Calibrator serves to calibrate and test Spark Testers up to 40 kV used for electrical testing of cable jackets and conductor insulations or tubes.

The following parameters of the Spark Tester can be tested:

- Test Voltage characteristics: DC voltage up to 40 kV, AC voltage (50/60 Hz) up to 40 kV, AC voltage high frequency (up to 4 kHz)
- Short-circuit current: up to 15 mArms DC, AC and impulse
- Fault detection: with an artificial fault simulator, the CALIBRATOR SP 40A generates an artificial fault according to the standard IEC 62230 for checking the function of the fault detector.



Dielectric Testing / Spark Test

Thousands of ZUMBACH Spark Testers have been detecting blank spots and faults in processes like:

- Insulating lines

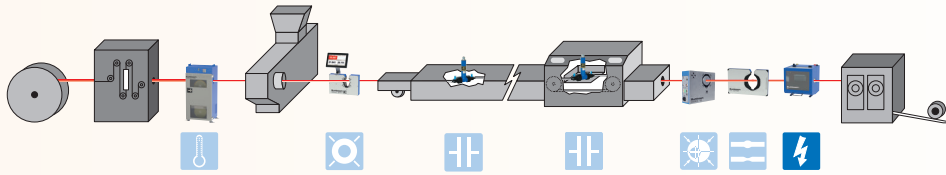

- Jacketing lines

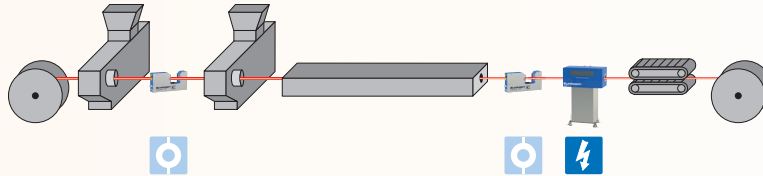

- Rewind / Confection lines

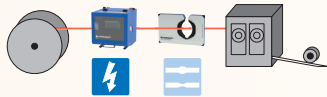

A Spark Tester for any application

According to various applications, ZUMBACH offers Mains Frequency, Direct Current and High-Frequency spark testers. Typically they are installed at the end of the cooling trough in extrusion lines or in rewinding processes and detect the smallest defects and bare patches in the insulation or sheathing of electrical wires and cables.

Model	AST L 15A/25A.50	AST L 15A/25A.90	AST L 15A/25A/40A.250
Max. product diameter	50 mm (1.97 in.)	90 mm (3.54 in.)	250 mm (9.84 in.)
Output voltage	2...15 kV / 2...25 kV	2...15 kV / 2...25 kV	2...15 kV / 2...25 kV / 2...40 kV

Model	AST H 15A	DST 10	DST 28A
Max. product diameter	30 mm (1.2 in.)	ø 30 mm (1.18 in.) with bead chain electrodes 30x30 mm (1.18 x 1.18 in.) with flat electrodes	ø 30 mm (1.2 in.) with bead chain electrodes ø 40 mm (1.57 in.) or 20...75 mm (.79 x 2.95 in.) with ring electrodes 60x30 mm (2.36 x 1.18 in.) or 150x30 mm (5.9 x 1.18 in.) with flat electrodes
Output voltage	0.5...15 kVac	0.5...10 kVdc	1...28 kVdc



VISU-Touch – Display and control unit (option) for all spark testers

This unit allows the manual control of the electrode unit. The VISU-Touch can be affixed on the electrode unit or used separately. For applications where the spark tester is controlled via an interface, the VISU-Touch can be used as a local display.



DST 10



DST 28A/AST H 15A

ZUMBACH Preheater – AUTAC 300



Inductive Conductor Preheater by ZUMBACH

Extrusion lines producing communication wire require optimum and repeatable conditions in order to produce valuable product at the highest speeds. Inductive preheating is clean and reliable. The adhesion is improved, humidity and other residues are removed from the conductor of data transmission cables (coax, Category 5 and higher). Many insulating materials can not be extruded successfully without preheating of the conductor. Cellular insulating materials require a uniform conductor temperature in order to produce a uniform cell structure and accurate electrical properties.

Important Features

- Appropriate preheater for any application
- Micro processor based
- Automatic self-checking feature
- Network ready
- Display of all relevant data
- Temperature measurement and control

Main Benefits of Wire Preheating

- Better product quality and improved consistency
- Higher line speeds are possible thanks to lower stress within the insulation material
- Shorter start-up times = less scrap
- Dielectric properties of the insulation material are more uniform and the process conditions are reproducible (important for data wires Category 5, 6, and beyond)
- Improved cell structure in case of foamed and foam/skin insulating material
- Preheating allows control of the bonding of the insulation material to the conductor
- Uniform conductor temperature maintained even during ramping phases
- Lasting improvements of the CpK value
- The aging characteristics of the insulation are improved substantially through better uniformity (reduced risk of insulation cracking due to mechanical stress, e.g. bending of the wire)
- Oil and water residues on the conductor surface are cleaned away by evaporation



AUTAC 300 – Wire temperature measurement – The perfect partnership for preheating

The AUTAC 300 is used for temperature measurement and control in applications with conductor preheating or post annealing stages. The system consists of a sensor and a processor unit. Non-contact and precise temperature measurement with "Convective Heat Flow Principle" from 10° C to 300° C on wires and cables with a diameter range from 0.2 mm to 7 mm (.008 in. to .28 in.).

The measurement is independent of influencing factors such as colour, emission, speed, material or surface structure meaning the wire. The measuring head is slotted and can be changed without interruption, there is no need to thread the wire.



Conductor Preheating / Temperature Control

Operating Principle of an Inductive Preheater

The wire to be heated is looped around the sheaves (pulleys) of the preheater and forms a resistive loop. Based on the resistance of the conductor material, on the line speed and on ambient and preheat temperature, a specific voltage is supplied to this loop by an inductor which induces a current. This heating current is induced inductively and without any contact to the product.

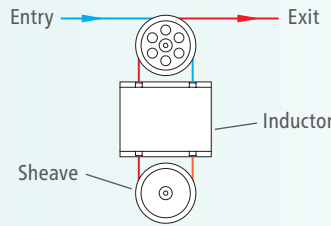

The target wire temperature can be directly set in degrees (C or F). The preheater will keep that temperature constant, even in case of line speed variations or changes of the conductor cross section.

Preheater In-Line with Other ZUMBACH Measuring Instruments

All ZUMBACH preheaters can easily be integrated into existing lines. Existing data ports allow networking with host systems and can be configured for "multi-drop" applications. Numerous other ZUMBACH measuring instruments offer comprehensive solutions for process monitoring and automatic optimization.

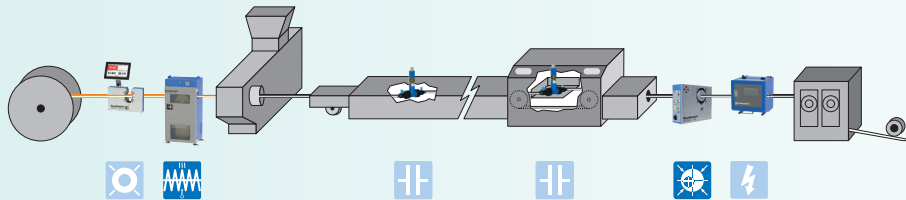

Model	WST.8A.7.20.400-x	WST.16A.12.20.400-x	WST.25A.12.20.400-x
Nominal heat power	8 kW	16 kW	25 kW
Sheave diameter	178 mm (7 in.)	305 mm (12 in.)	
Wire diameter	1.5 - 2 mm (.06 - .08 in.)	2 - 2.8 mm (.08 - .11 in.)	2 - 3.8 mm (.08 - .15 in.)
Min. - Max. Ø (geometrical)	.32 - 3.5 mm (.01 - .14 in.)	.32 - 5.70 mm (.01 - .22 in.)	
Line speed	6 - 2500 m/min. (19.7 - 8202.1 ft./min.)		
Max. wire temperature	200 °C (392 °F)		
Line height	980 - 1130 mm (3.22 - 3.71 ft.)		
Dimensions (w x d x h)	520 x 500 x 1310 mm (20.47 x 19.68 x 51.57 in.)	680 x 560 x 1340 mm (26.77 x 22.04 x 52.75 in.)	
Weight approx.	210 kg (462 lbs.)	330 kg (727 lbs.)	
Mains voltage (L1, L2, L3, PE)	400 - 460 VAC		
Mains frequency	50 / 60 Hz		
Current consumption max.	14 A	28 A	57.2 A
Integrated interfaces	EN-Ethernet TCP/IP service interface plus optionally one of: – RS: Serial RS-232/-422/-485 host interface – DP: Profibus DP host interface – EN: Ethernet TCP/IP host interface – PN: Profinet IO host interface – EI: EtherNet/IP host interface		



VISU-Touch – Operator Station



Rugged and compact 10 Point P-CAP Touch Screen. Easy installation of operator display at a remote location – Convenience for the operator. Allows for the operator to set up the preheater and turn on/off without being local to the preheater (requires optional connection cable).

USYS Software



Total In-Line Process and Quality Control

ZUMBACH has the solution for all quality parameters. USYS systems process measurement data from a variety of sensors and communicate with the user and with host computers. USYS processors also control extrusion lines or other manufacturing lines with intelligent self-adapting controllers, SIGMA-EXPERT and Cpk-Pilot.

Communication and Networking

Today, the ability of sensors or processors to communicate with other computers or networks is essential. Therefore more and more ZUMBACH sensors have direct communication ports. For all other cases ZUMBACH offers a variety of interface units and USYS software to satisfy almost any need and concept.

CI Interface Boxes

Wherever a sensor has to communicate directly with a PC or PLC, ZUMBACH offers compact boxes with data ports, RS-232, -422, -485, Profibus DP, Ethernet TCP/IP, Profinet IO V2.3 and EtherNet/IP.



CI 1J/EN-EN (Ethernet TCP/IP) CI 1J/EN-RS (serial) CI 1J/EN-DP (Profibus DP)
 CI 1J/EN-PN (Profinet IO)
 CI 1J/EN-EI (EtherNet/IP)

USYS Data Log

Windows™ based software for easy data collection from one or several ZUMBACH processors and for saving the data in text or Excel™ files.

™ Windows and Excel are trademarks of Microsoft Corporation

USYS Web Server

This optional software enables the display of information from USYS processors at remote terminals. Communicates via LAN. Viewing with an Internet Explorer or other.

USYS Report Manager

Historical storage of all printed reports, trends and SPC. Simple XML viewer for traceability and re-print possibility (ISO 9000 focussed).

OPC UA

The OPC UA technology is a standard in the area of process control such as SCADA or HMI. Integrated in the USYS 200 and USYS IPC 1e/2e models.



Processors for any Application, Product and Budget

Common to all ZUMBACH processors is:

- Very easy to use
- Robust and stable
- No data loss or crashes
- Flexible, upgradeable

Depending on version, **USYS** fulfils a number of tasks, e.g.:

- Graphic/numerical display of all quality parameters
- Tolerance alarms
- Large product library
- Summaries of all kind
- SPC statistics
- SIGMA-EXPERT control and CpK-Pilot

VISU-Touch



Low cost display and alarm unit.

USYS 20



Economic and universal processor in various versions. For extrusion and other processes, including controller, mini statistics, alarms, interfacing.

USYS 200



Processor for 1 ODAC or MSD sensor or 1 CAPAC or ODEX system plus auxiliary functions: alarms, controller, statistics, interfaces.

USYS IPC 1e / USYS IPC 2e



Processor for 1 to 6 ODAC or MSD sensors, 2 CAPAC systems, ODEX systems, UMAC scanners, 4 controllers, plus auxiliary functions: alarms, controller, statistics, interfaces.

Display	7" LCD with LED	4.2" LCD monochrome	6.4" TFT LCD	Option: 19" Touch Screen
Graphics, trends			●	●
Max. number of measuring systems	1	1	1	3 (USYS IPC 1e) 6 (USYS IPC 2e)
ODAC/MSD sensors	1	1	1	3 (USYS IPC 1e) 6 (USYS IPC 2e)
CAPAC systems	1	1	1	1 (USYS IPC 1e) 2 (USYS IPC 2e)
ODEX systems	1		1	2 (USYS IPC 1e) 2 (USYS IPC 2e)
Spark tester, fault detector (KW)	●		●	●
Serial ports		2	2	6 (USYS IPC 2e: + 4 optionally)
Analog outputs		1	1	Up to 10 (2 x Standard)
Printer ports		Serial	USB, Parallel, Network	USB, Parallel, Network
Controllers		●	1	4 (option Hot-Cold)
SPC statistics		Text only	●	●
USYS Data Log software	Option	Option	Option	Option
USYS Web Server software	Option		Standard	Standard
USYS Report Manager software	Option		Option	Option
OPC UA Software	Option	Option	Option	Option

Control Algorithms

USYS systems work with sophisticated control software for efficient material saving.

SIGMA-EXPERT Control and CpK-Pilot

Intelligent, self-adapting system for dynamic control. With CpK-Pilot the target value will automatically be optimized to the lower specification limit.

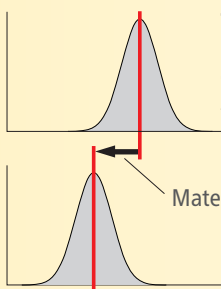

Hot-Cold Control

ZUMBACH systems with one measuring head each at the beginning and at the end of the cooling trough use SIGMA-EXPERT control software in order to compensate automatically for the shrinkage from "hot" to "cold" diameter. This function can be used individually or in combination with diameter and capacitance sensors for compensation of the "hot-cold" variations (control of expansion).

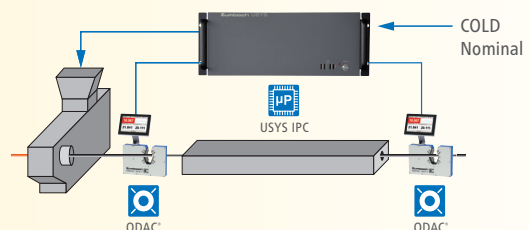

PROCESS CONTROL SYSTEMS FOR MULTIPLE SENSORS

JACKETMASTER • CELLMASTER • WALLMASTER • ODEXMASTER • RAYEXMASTER • BARMASTER



For all extrusion processes or other operations, from wire drawing to the finished cable, and for all instrumentation configurations there is a suitable USYS processor and software package. Depending on the application and customer requirements, these USYS processors are grouped in **JACKET-**, **CELL-**, **WALL-**, **BAR-**, **ODEX-** and **RAYEXMASTER** systems. All USYS processors can easily be networked and are ready for Industrie 4.0.

Single Extrusion

Extended instrumentation:

- **ODEX**[®] eccentricity / concentricity and diameter gauge (insulation) or
- **UMAC**[®] wall thickness gauge (jacketing)

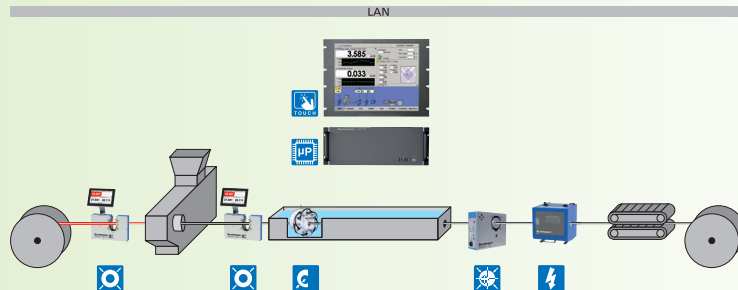

Tandem Extrusion

Extended instrumentation:

- **ODEX**[®] eccentricity/concentricity and diameter gauge (insulation) or
- **UMAC**[®] wall thickness gauge (jacketing)
- Fault detectors etc.

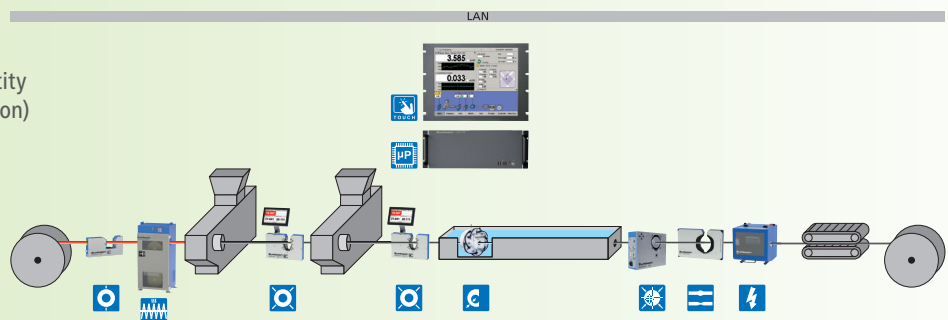

Control of "foam" and "foam skin" as well as solid insulation

Based on USYS IPC, these 3-loop systems measure, monitor, and control simultaneously in real time diameter, capacitance and degree of expansion.

- Data cable, cat. 5, 6...8
- Telephone singles
- Coax and other communication cable

If needed, a "hot-cold" control for capacitance and/or diameter is also available.



Advantages / Features

- Easy operation
- Sophisticated software and 3 controllers (2 static) for:
 - screw rpm or line speed
 - position of telescopic cooling trough/quench point
 - temperature of the heat zone(s)
- Retrofit onto existing lines without problem
- Total communication with host or PLC, thanks to comprehensive protocol, USYS Data Log*, USYS Web Server*, USYS Report Manager* and OPC UA*
- Available as OEM version

*Ask for detailed data sheets

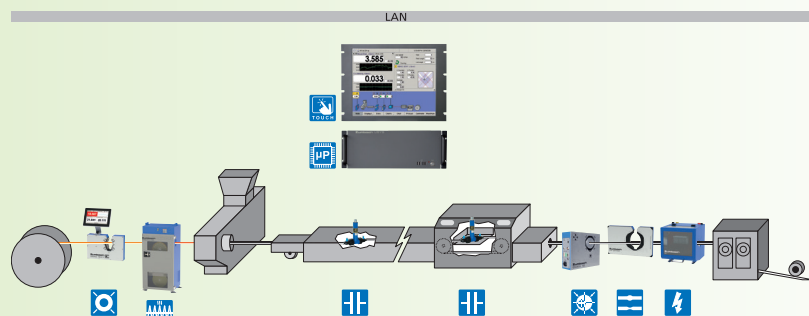

► Due to the number of application possibilities, we are unable to show all line configurations.

LSV – LASER SURFACE VELOCIMETERS

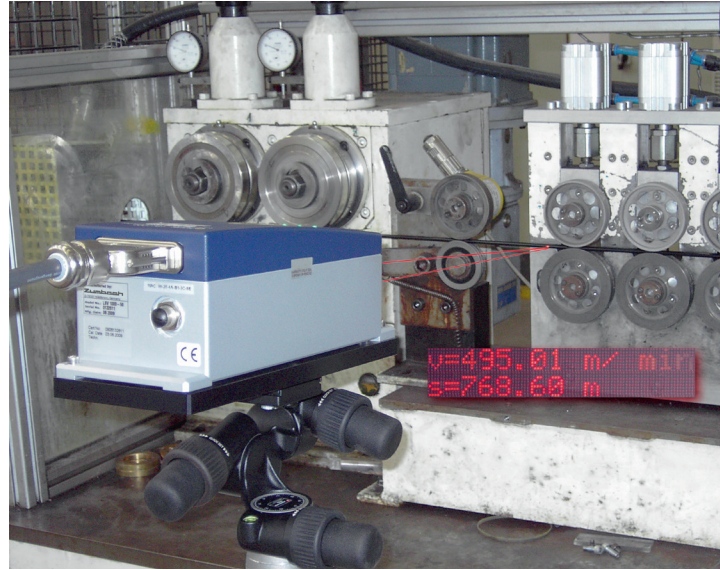
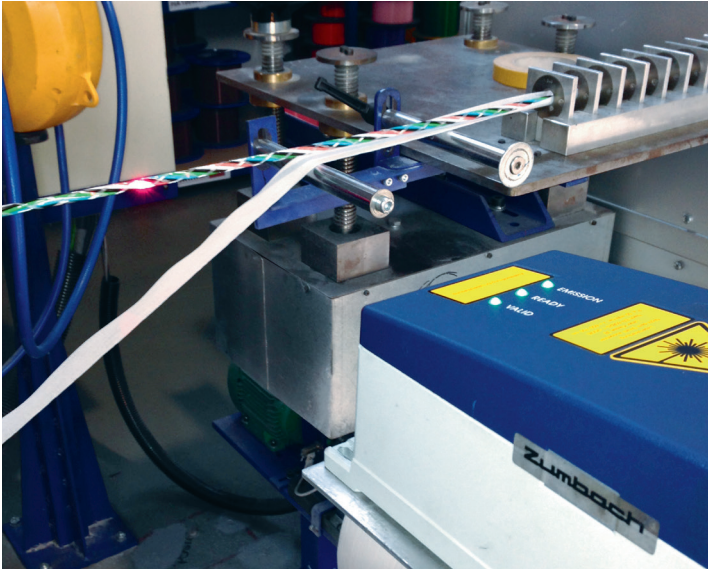

Non-contact Precision Speed and Length Measurement

Precision speed and length measurements are critical for optimization of continuous or quasi-continuous production processes. Proper utilization of these measurements can lead to lower production costs and higher product quality. The ideal sensor must exceed traditional contact encoder performance, increasing reliability and accuracy while minimizing maintenance requirements and material yield. The LSV Laser Surface Velocimeters have been designed as the ideal next generation sensors for non-contact length and speed measurement. They provide precise length and velocity data quickly and reliably for both process control and cut-to-length applications.

Compact, Reliable, Inexpensive and Profitable

- Zero speed, direction detection
- Reduced operating and maintenance costs
- Attractive ROI, fast payback
- All-in-one system, easy integration into production processes and control environments
- Easy to operate and no re-calibration required
- Visible laser for easy alignment in the field
- Robust sensor technology for reliable operation even under harsh conditions, protection classes IP 66 and IP 67
- Fast, state-of-the-art signal processor with powerful command set for efficient system communication via serial or Ethernet interface
- Includes two trigger inputs for additional light barriers or optical switches for high precision edge detection and offset length compensation
- Hardware status signals for remote diagnostic functions available
- User-selectable full quadrature pulse output and interfacing as LAN & RS-422

Metrological Properties	LSV 1100	LSV 2100 (zero speed, automatic direction detection)
Nominal working distance	300 mm (11.81 in.)	300 mm (11.81 in.)
Min. velocity	0.50 m/min (1.64 ft/min)	0 m/min (standstill) (0 ft/min)
Max. velocity	6000 m/min (19'685 ft/min)	± 7700 m/min (25'262 ft/min)
Depth-of-field	80 mm (3.15 in.)	120 mm (4.72 in.)
Accuracy	<0.05 % of reading (under controlled conditions)	
Reproducibility	<0.02 % of reading (under controlled conditions)	

Connection Box



Compact terminal box



Mobility Kit



Cooling Plate



Touch display



Air wipe with exchangeable window



Mounting platform

ODAC® / STEELMASTER

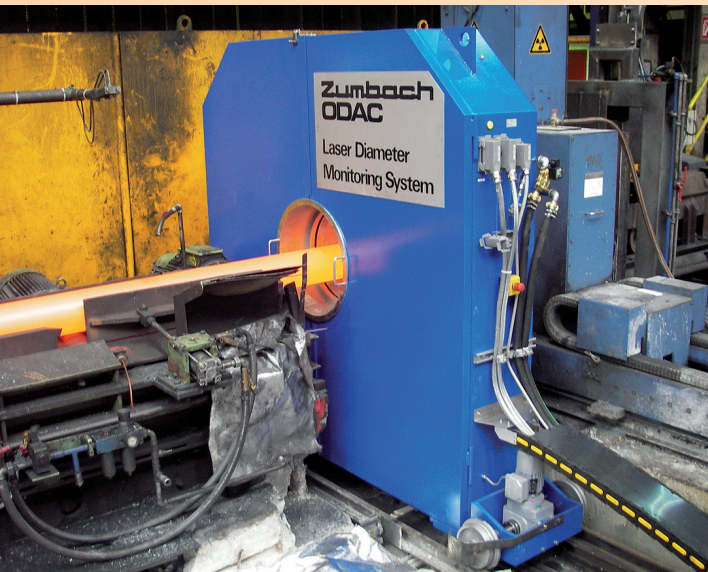

Non-Contact, Dimensional Measurement Systems for In-line and Off-line use, and for Monitoring Processes under Difficult Conditions. Steel Industry, Metals, Glass, Chemical Industry.

A combination of ODAC® laser measuring heads, proven by the thousands, USYS real-time processors and PCs with application specific STEELMASTER software, offers a solution to practically any measuring problem. Highly developed protection and motion devices guarantee reliable measurements, even under the most severe conditions.

In MULTIGAUGE mode, 1 STEELMASTER PC can process and monitor data of up to 4 gauges, depending on the configuration. Additional STEELDATABASE software is available for extensive data archiving and re-viewing.

Typical Solutions for Temperatures up to 1200° C

- Hot rolled products:
 - Wire
 - Steel Rod
 - Rebar
 - Steel Profiles
 - Seamless Pipe
- Continuous casting – rolling
- Forging (also Off-line)
- Extrusion of steel
- Glass, casting/drawing

Key Data

Product dimensions	0.1...1000 mm (.004...39.4 in.)
Material, colour	Any
Principle	Laser scanning
Scan rates	Up to 2000/s/axis
Repeatability	Up to 0.002 mm (.00008 in.) depending on gauge type

Typical Displays of the STEELMASTER System

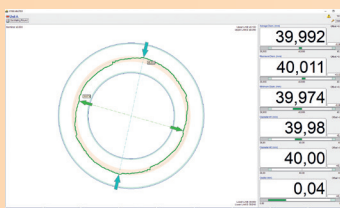

Round

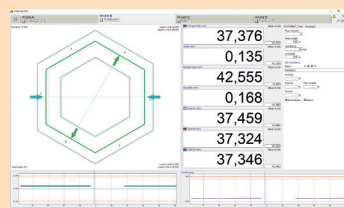

Hexagon

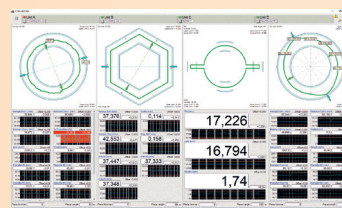

Simultaneous display of 4 measuring units



For Hot Rolling and Processes in Harsh Environments

Measuring Systems for Hot Processes

basically consist of the following elements:

- Multiple **ODAC** laser measuring heads
- Protection unit for measuring heads
- Cooling systems water and/or air
- PC based data processing and display unit
- Filter/blower unit for air purging of laser openings
- Remote displays and giant displays
- Mobility hardware



Depending on requirements, dictated by product and process, the system is assembled from standard components in optimal fashion.

Systems

Typical for

Static, single-axis ECOGAUGE systems with modular laser, emitter and receiver.

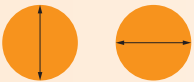

- Continuous casting
- Billets
- Steel rod
- Pipe
- Glass
- Quartz
- Plasma

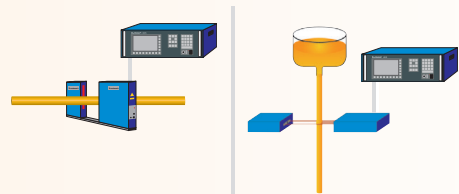

Static STEELMASTER SMS systems with 2, 3, 4 or 6 measuring axes. Integrated, compact design.



For measurements of several diameters over the total length, e.g.:

- Steel rod after finishing
- Pipe after calibration stand



Oscillating STEELMASTER SMO systems or multi-mode systems oscillating-static with 1, 2, or more measuring axes. Integrated, compact design.



For cases, where the complete diameter profile has to be covered.

- Steel wire and steel rod after final stand
- Seamless pipe after calibrator

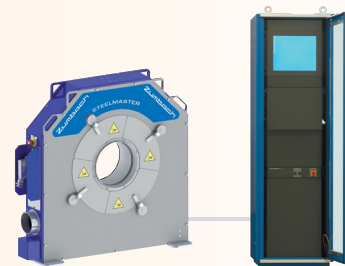

Rotating STEELMASTER SMR systems with up to 3 measuring axes. Novel, highly compact device with revolutionary rotational measurement technology and unique, fully contact-free transmission of both power and measurement signals.



For fastest measurement of hot and cold rolled steel. Captures up to 10 complete profiles/second.

- For all high speed rolling mills with 2- and 3-roll technology
- Also suitable for short product lengths

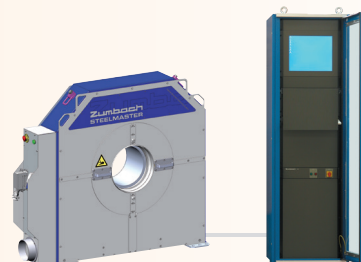

ODAC® / USYS SYSTEMS / DIAROND / BENDCHECK

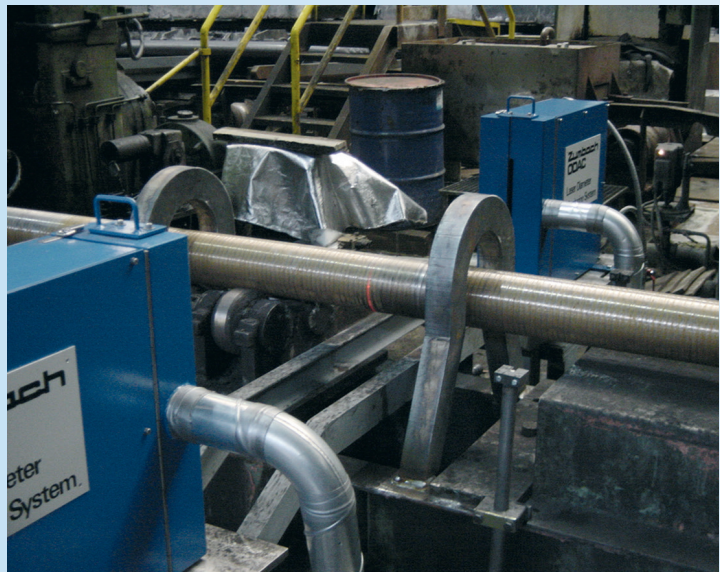

Non-Contact On-line and Off-line Dimensional Measurement Monitoring under Industrial Conditions. Steel Industry, Metals, Glass, Food, Packaging, Paper.

By using one or several ODAC measuring heads in combination with a USYS processor and application specific software, practically every measuring problem can be solved in an optimum way. Where needed, optional protection devices are available for reliable operation.

Typical ODAC® Measuring Heads

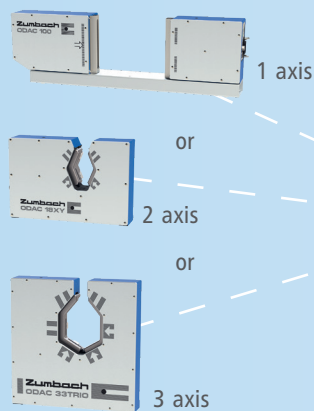

Typical USYS Processor

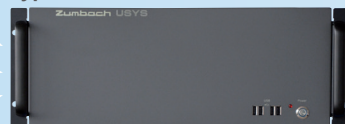

Typical Screens



Non-Contact In-line Measurement of Diameter and Roundness. For round rod, bar and tubes – for finishing, peeling, grinding, straightening, quality control (NDT).

The solution

A high-precision, 3-axes laser head ODAC® TRIO measures at high frequency and fully synchronized, 3 x diameters at 60° offset to each other, and 6 x corresponding tangent points on the periphery of the product. All measured values are stored in the USYS IPC processor. For completing the whole profile there must be a self rotation of the product of at least 60° or a rotation of the measuring head by means of a rotary device. An angle information is not required. Without rotation, there can also be statistical evaluation of a number of parts, where results can be enhanced by any random manual oscillation or orientation.

Data capturing

The 3 synchronized scans yield an "instant picture" of the position of 6 shadow edges ($Se_1 - Se_6$) of the product, related to an internal coordinate system and 3 precise diameters d_1, d_2 and d_3 .

3-axis measurement

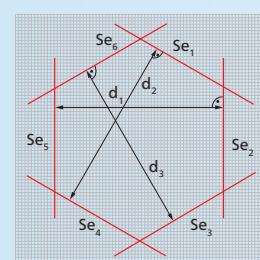
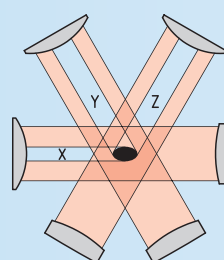



Precise Diameter Measurement and Control in all Processes

There are a few application problems where ODAC/USYS combinations do not allow for continuous measurement and control, while guaranteeing maximum accuracy and quality of the end product.

Extrusion

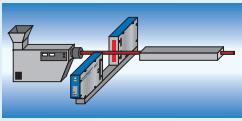

Plastic, Cable, Rubber, Food, Sausage Casings, Pastes

Braiding, Taping

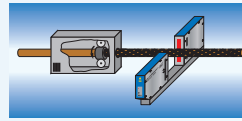

Rope, Cable, Hose, Textiles, Cardboard tubes

Peeling / Polishing

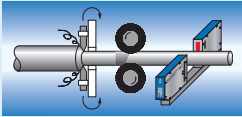

Grinding

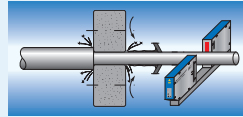

Slitting (width of strips)

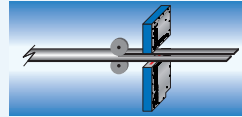

Tube Welding

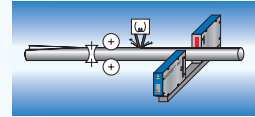

Rolling

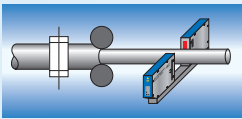

Drawing

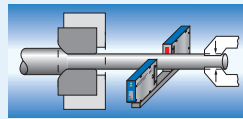

Straightening

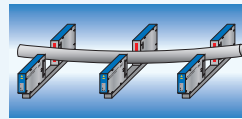

Testing / Sorting

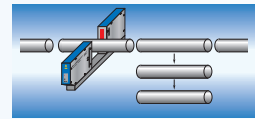

For Each Process and Each Product the Optimal System

For each process, each product, and each budget, the required components are available, including:

- Measuring heads – 1, 2, 3 or more axes
- Processor for 1 or several sensors
- Specific software
- Protection, cooling etc.
- Peripherals, networking

Advantages

- Dimensions continuously in control
- Faster start-ups, less scrap
- Automatic control
- Instant recognition of anomalies
- Trend display
- Statistics, SPC charts
- 100% Quality control
- Documented quality

BENDCHECK – Straightness measurement of Bars and Pipes

This non-contact measuring solution opens tremendous potential to tube and bar manufacturers for in-line quality assurance and is achieved without laborious, manual measurements. ZUMBACH's BENDCHECK system is installed in-line and measures the straightness of every single product passing through the measuring station without slowing down the production process.

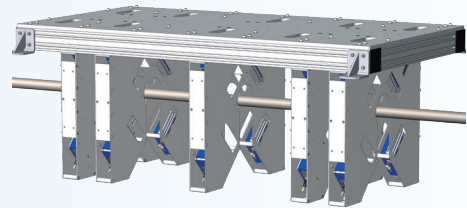

PROFILEMASTER® – In-line profile measurement using light section principle and machine vision

The dimensions or even the complete cross-section of profiles and pipes made of steel and metal must be continuously measured and monitored in the manufacturing process. The PROFILEMASTER systems represent an accurate and economical solution to the problem. 1 or up to 8 laser/camera modules measure the cross section of the moving profile. A powerful PC based processor adds the partial pictures of the cameras made up of straight lines and radii together to yield the momentary cross section of the profile. All relevant dimensions such as width, height, angle and radii are added together to form the full cross-sectional picture.



Advantages

- Modular systems with up to 8 cameras measure in real time any shape of the moving profile
- Shape fault detection (SFD) thanks to high sampling rate
- Detects process problems in an early stage
- Makes post production measurements irrelevant



Rebar software option allows additionally the measurement of specific features such as core diameter, overall diameter and rib height.

Solutions for Special Processes

Unprotected or partially protected systems at a reduced cost are available for cold processes or where only medium temperatures are present.

- Continuous casting/rolling of copper and aluminium rod
- Extrusion of Aluminium, Brass, Lead
- Thermal treatment, cooling
- Cold rolling and drawing
- Quality control lines (NDT)



Pivoting system ($\pm 10^\circ$)

For height and/or width. Recommended when product position unstable and not aligned with laser beam.

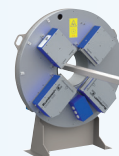

Oscillating system ($\pm 180^\circ$)

For irregular, non-round products. Min, Max, Avg. diameter (e.g. continuous casting, rolling).

Worldwide Sales and Service Network

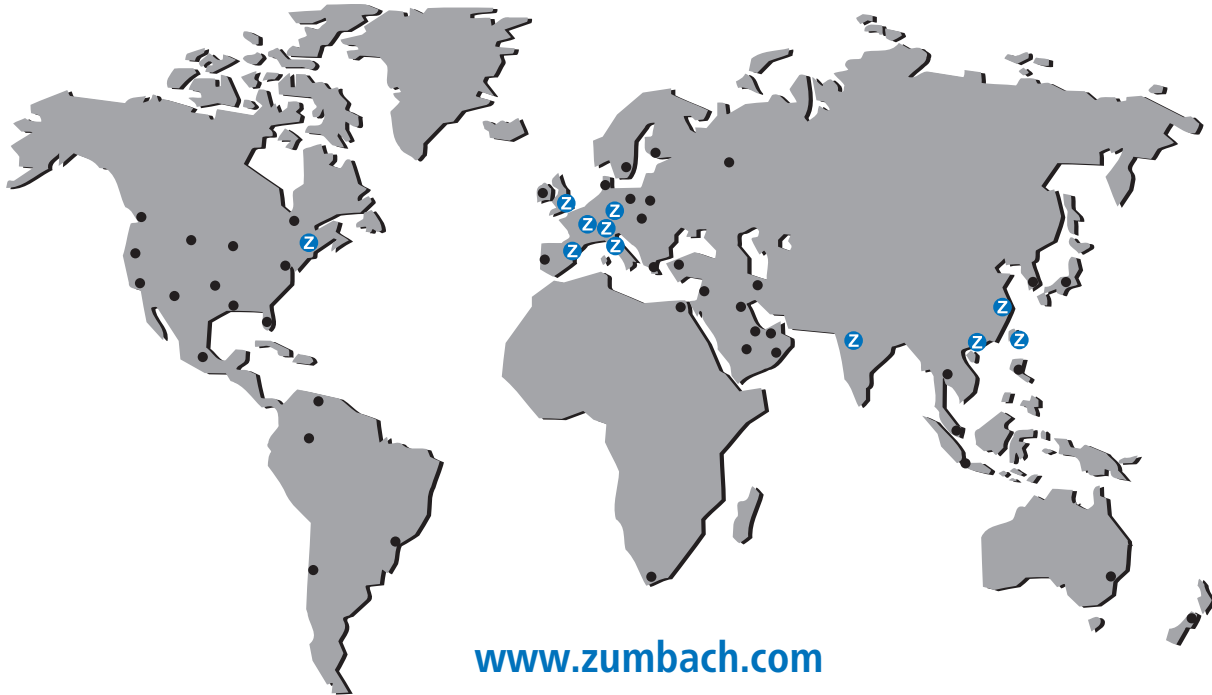

The ZUMBACH Group

Switzerland (H.Q.)
Zumbach Electronic AG
P.O. Box
CH-2552 Orpund
Phone +41 (0)32 356 04 00
Fax +41 (0)32 356 04 30
E-mail: sales@zumbach.ch

Benelux
Zumbach Electronic AG
Phone +32 (0)52 31 18 81
Fax +41 (0)32 356 04 30
E-mail: sales@zumbach.be

China P.R.
Zumbach Electronic (Shanghai) Co., Ltd.
2F, Building 18
No. 481 Guiping Road
200233 Shanghai, P.R. China
Phone +86 (0)21 542 60 443
Fax +86 (0)21 542 61 151
E-mail: sales@zumbach.com.cn

Czech Republic
Zumbach Czech Office
Hutska 126
CZ-27201 Kladno
Phone +420 608 474 664
Fax +41 (0)32 356 04 30
E-mail: jvorlicek@zumbach.cz

France
Zumbach Bureau France
6 rue de l'Avenir
FR 77760 La Chapelle La Reine
Phone +33 (0)1 64 24 46 31
Fax +33 (0)1 64 24 46 26
E-mail: ventes@zumbach.com.fr

Germany
Zumbach Electronic GmbH
Alfred-Nobel-Straße 9
DE-50259 Pulheim-Brauweiler
Phone +49 (0)2234 68293-00
E-mail: verkauf@zumbach.de

India
Zumbach Electronic India Pvt. Ltd.
S No: 106/2/1, 2nd lane, "Daffodils" Society
Row House No: 7, Near Karnataka Bank,
Behind D mart, Baner Mahalunge Road,
Baner, Pune - 411045
Maharashtra
Mobile +91 9890 100 813
E-mail: sales@zumbachindia.com

Italy
Zumbach Electronic Srl
Via Adua, 19
IT-21045 Gazzada Schianno (VA)
Phone +39 0332 870 102
Fax +39 0332 464 605
E-mail: zumit@zumbach.it

Spain
Zumbach Electrónica S.L.
Avinguda de Cornellà, 144, 3^a, 3^a
ES-08950 Esplugues de Llobregat
(Barcelona)
Phone +34 93 666 93 61
E-mail: gestion@zumbach.es

Taiwan R.O.C.
Zumbach Electronics Far East
4F, No. 262, Sec. 6
Ming-Chuan E. Road
Taipei, Taiwan R.O.C.
Phone +886 2 2630 5530
Fax +886 2 2630 5529
E-mail: info@zumbach.tw

United Kingdom
Zumbach Electronics Ltd.
Registered Office Address:
22 Cromwell Business Centre
Howard Way, Newport Pagnell
Milton Keynes, MK16 9QS.
Phone +44 (0)870 774 3301
Fax +44 (0)870 774 3302
E-mail: sales@zumbach.co.uk
Company Registered in England
Company Registration Number: 1233358

USA
Zumbach Electronics Corp.
140 Kisco Avenue
Mount Kisco, NY 10549-1407
Phone +1 914 241 7080
Fax +1 914 241 7096
E-mail: sales@zumbach.com



• ZUMBACH Agencies

Arab Emirates, Australia, Brazil, Denmark, Egypt, England, Greece, Indonesia, Israel, Japan, Korea, Malaysia, Mexico, Oman, Poland, Portugal, Qatar, Romania, Russia, Saudi Arabia, Serbia, Singapore, Slovenia, South Africa, Sweden, Taiwan, Thailand, Turkey, Vietnam.