

Zumbach

SWISS PRIME MEASURING SINCE 1957

CAPAC[®] HS

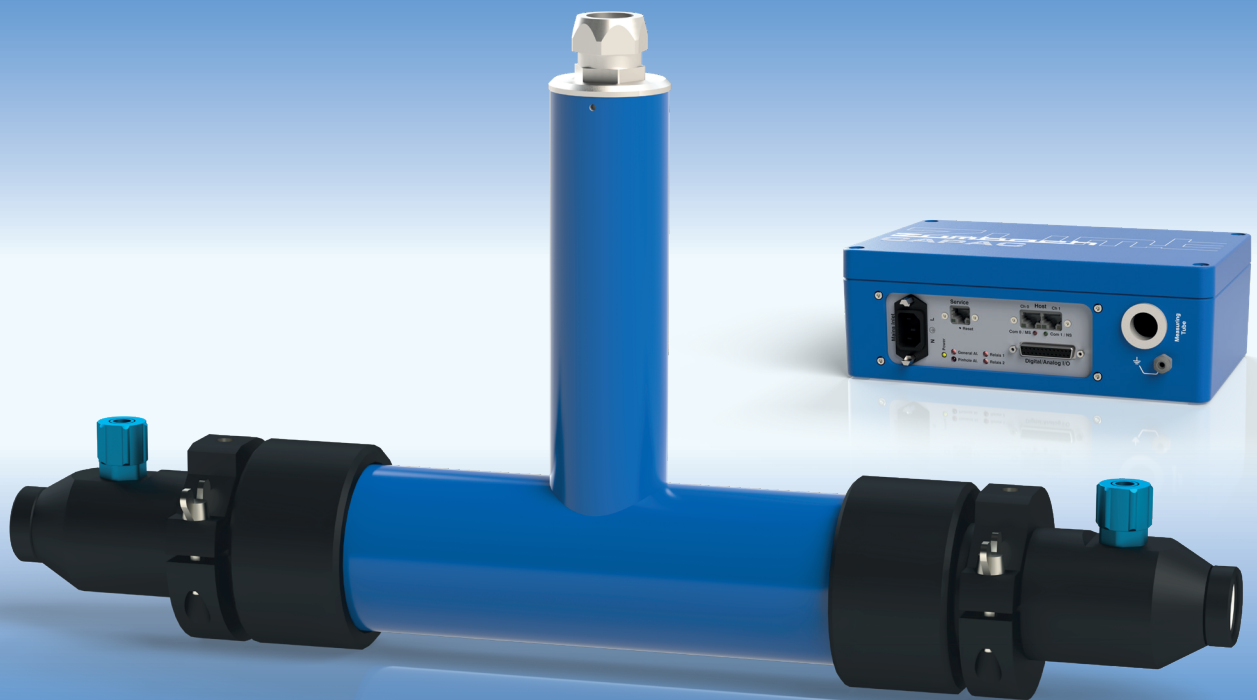

Capacitance Measurement Systems
for Cable Production Lines

IN-LINE CAPACITANCE MEASURING SYSTEMS

The **CAPACHS** measuring system measures the coaxial capacitance of plastic-sheathed conductors with high accuracy during the production process. The measuring system is used wherever precise knowledge of the core capacitance is a decisive quality feature, such as in the production of fully and cellular PE-insulated inner conductors for HF and CATV cables as well as in the extrusion of data and LAN cables (Cat. 5, 6, 7, 8). With the following possibilities:

- Accurate, continuous measurement and monitoring of the core capacitance
- High measurement bandwidth with low noise level
- FFT analysis and absolute value measurement possible simultaneously
- Determination of return loss SRL up to 6.5 GHz
- PINHOLE function: detection of holes and bare spots in the insulation
- Flexible communication with higher-level computer systems (host)
- Statistical monitoring and logging of production
- Recording of the produced length via length encoder input
- Digital inputs and outputs for connecting peripheral devices and control elements
- Very fast potential-separated analogue output with selectable bandwidth
- Can be used as a fault detector in jacketing lines
- Measuring tubes with different inner diameters and active measuring lengths available

SYSTEM OVERVIEW

The measuring tube is the actual measuring component of the solution. The electronics unit supplies the measuring tube with a high frequency sinusoidal base signal, which the measuring tube reflects back to the electronics unit as a proportional current level depending the true capacitance of the product passing through the measurement tube. The electronics unit process's this captured current signal to give onward measurement results and statistics through its available interfaces.

Data processing and display units from ZUMBACH (**USYS 20, USYS 200, USYS IPC 1e/2e, VISU-Touch**) or customer systems, such as PLC's and Host computers.

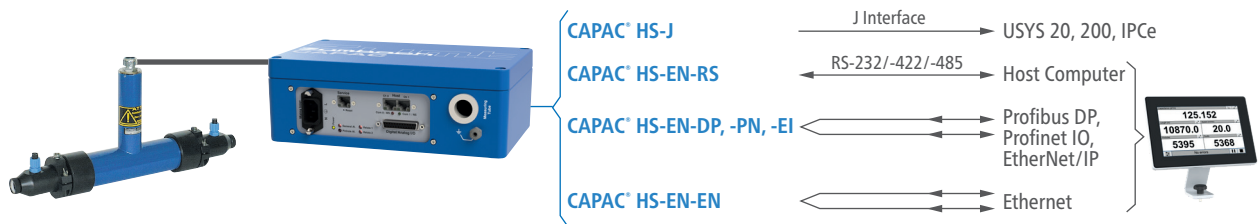

MEASURING TUBES

Standard tubes with a measuring length of 50 mm (2 in.)

These measuring tubes are specially designed for the measurement of CAT type communication cables. These tubes feature a very high signal to noise ratio as well as a large band width. This is especially advantageous when capacitance variations must be monitored e.g. for FFT/SRL analysis.

Model	MR.12.50HS		MR.12.50HSD ¹⁾		MR.36.50HS		MR.68.50HS	
	mm	inch	mm	inch	mm	inch	mm	inch
Inner diameter	12	0.5	12	0.5	36	1.4	68	2.7
Max. conductor diameter ²⁾	8	0.3	8	0.3	24	0.9	45	1.7
Total length (over all)	276	10.9	444	17.5	734	28.9	1204	47.4
Active measuring length	50	1.9	50	1.9	50	1.9	50	1.9
Measuring frequency	80 kHz / 2.0 VAC							
Weight	3.3 kg / 7.2 lbs		4 kg / 8.8 lbs		7.4 kg / 16.3 lbs		15.4 kg / 34 lbs	
Max. water temperature	70°C / 158°F		70°C / 158°F		70°C / 158°F		60°C / 140°F	



Ultra short tubes with a measuring length of only 10 mm (0.4 in.)

Drawing from a vast experience with thousands of measuring tubes of a variety of models, ZUMBACH has developed an extremely short but accurate measuring tube with an electrode length of a mere 10 mm (.39 in.) for high frequency coaxial cables. These tubes feature a surprisingly low noise level and meet the highest demands for absolute accuracy and bandwidth with the following advantages:

- High length resolution with low noise level
- SRL prediction up to 6.5 GHz
- 600Hz bandwidth of the measuring system
- High absolute accuracy
- Compact and robust design

Model	MR.12.10HS		MR.12.10HSD ¹⁾		MR.36.10HS		MR.68.10HS	
	mm	inch	mm	inch	mm	inch	mm	inch
Inner diameter	12	0.5	12	0.5	36	1.4	68	2.7
Max. conductor diameter ²⁾	8	0.3	8	0.3	24	0.9	45	1.7
Total length (over all)	276	10.9	444	17.5	734	28.9	1204	47.4
Active measuring length	10	0.4	8	0.3	10	0.4	10	0.4
Measuring frequency	80 kHz / 2.0 VAC							
Weight	3.3 kg / 7.2 lbs		4 kg / 8.8 lbs		7.4 kg / 16.3 lbs		15.4 kg / 34 lbs	
Max. water temperature	70°C / 158°F		70°C / 158°F		70°C / 158°F		60°C / 140°F	

¹⁾ MR.12.50.HSD equipped with pressure chamber.

²⁾ Indicative value only; the max. diameter depends on the largest cable diameter to be expected.

ELECTRONICS

The electronics unit acts as the interface to the end user, be that through a Zumbach USYS processor/display, VISU-Touch web display or through any of the optional host interfaces. The electronics unit has as standard a Webserver interface allowing full unit operation and configuration over any connected Web browser. A standard Ethernet TCP/IP (PoE) Power over Ethernet service port allows for unit configuration or networking to a customer network. Additional Host interfaces are available optionally, including serial RS, Profibus DP, Profinet IO, Ethernet TCP/IP and EtherNet/IP.



In addition are 4 x digital relay outputs, 2 x length encoder inputs, 2 x digital inputs for statistics control and 1 x analogue output of measured capacitance. The electronics unit has its own integrated power supply for direct connection to local mains power supplies.

Main data	CAPAC HS all versions		
Capacitance measuring range (selectable)	Metric standard: 0..300 pF/m, extends: 0..600 / 0..900 / 0..1800 pF/m Imperial standard: 0..100 pF/ft, extends: 0..200 / 0..300 / 0..600 pF/ft		
Accuracy	Measuring resolution 16 bit, Display resolution (selectable) 0.001 pF/m / 0.0005 pF/ft		
Active meas. tube length 10 mm	MR.12.10HS/HSD	MR.36.10HS,	MR.68.10HS
Repeatability	± 0.020 pF/m / ± 0.007 pF/ft	± 0.033 pF/m / ± 0.011 pF/ft	± 0.040 pF/m / ± 0.013 pF/ft
Measurement accuracy	± 0.1 pF/m + 0.3 % from measured capacitance ± 0.05 pF/ft + 0.3 % from measured capacitance		
Active meas. tube length 50 mm	MR.12.50HS/HSD	MR.36.50HS	MR.68.50HS
Repeatability	± 0.018 pF/m / ± 0.006 pF/ft	± 0.018 pF/m / ± 0.006 pF/ft	± 0.018 pF/m / ± 0.006 pF/ft
Measurement accuracy	± 0.1 pF/m + 0.2 % from measured capacitance ± 0.05 pF/ft + 0.2 % from measured capacitance		
Pinhole / Blank Detection	Adjustable sensitivity		
Fault detection	Adjustable sensitivity in %		

Operation conditions / Miscellaneous	
Ambient temperature	Operating: 0...45° C, Transport / Storage: -20...50° C
Max. atmospheric humidity	95% (non condensing)
Altitude	0...3000 m (0...9843 ft.) over sea level
Pollution level	2 (only light non-conductive pollution)
Type of protection	Case IP 52 for vertical mounting otherwise IP 40, connection plate IP 40
Weight	3.1 kg (6.83 lbs)

Operation conditions / Miscellaneous						
CAPAC HS	-EN-RS	-EN-DP	-EN-EN	-EN-PN	-EN-EI	-J
Interface Service	Ethernet TCP/IP, RJ45 10/100BaseT, galvanically isolated					Only J interfaces to Zumbach processors: USYS 20/200, USYS IPCe, CI 1J/EN-RS, -DP, -EN, -PN, -EI
	RS-232/-422/-485, D-sub. connector, 9 p./m, galvanically isolated	Profibus DP (RS-485), D-sub. connectors 9 p./f, galvanically isolated	Ethernet TCP/IP, 2 x RJ45, 0/100 BaseT, galvanically isolated	Profinet IO, 2 x RJ45 10/100BaseT, galvanically isolated	EtherNet/IP, 2 x RJ45 10/100BaseT, galvanically isolated	

USYS option: FFT / SRL

The CAPAC® systems from ZUMBACH meet all the requirements for on-line prediction of structural return loss during the cable production process. These predictions are based on an FFT analysis of actual measured cable parameters. With ZUMBACH's option USYS, early detection of periodic irregularities resulting from the manufacturing process is possible during the production stage.

FFT Analysis – Fast Fourier Transformation

Particularly during the manufacture of communication cables, periodic fluctuations of capacitance and diameter alter the performance of the data transmission. The on-line FFT analysis of the measured data represents a powerful monitoring tool for the determination of periodically occurring irregularities during the cable extrusion.

SRL Prediction of the Structural Return Loss

The most commonly used method for quality control is to measure the return loss over the frequency bandwidth to be transmitted by the cable.

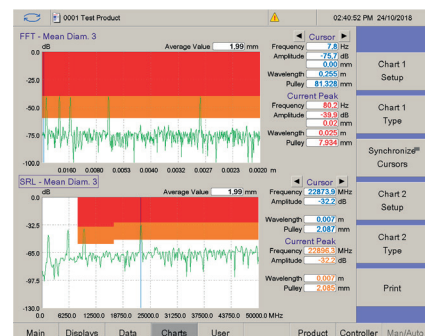

DIMENSIONS

MR.xx.50HS

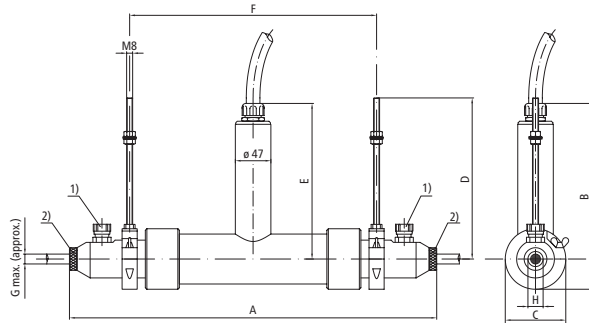

1) Nicht für / Not for / Ne pas pour: MR.36 / MR.68
2) Nicht für / Not for / Ne pas pour: MR.68

Model	A	B	C	D	E	F	G	H
MR.12.50HS	276 (10.86)	253 (9.96)	96 (3.78)	223 (8.78)	205 (8.08)	102-138 (4.02-5.43)	8 (0.31)	12 (0.47)
MR.36.50HS	734 (28.89)	270 (10.63)	100 (3.94)	223 (8.78)	220 (8.66)	424-654 (1.67-25.75)	24 (0.94)	36 (1.42)
MR.68.50HS	1204 (47.40)	330 (12.99)	160 (6.30)	238 (9.37)	250 (9.84)	385-1135 (15.16-44.69)	45 (1.77)	68 (2.68)

MR.12.50HSD

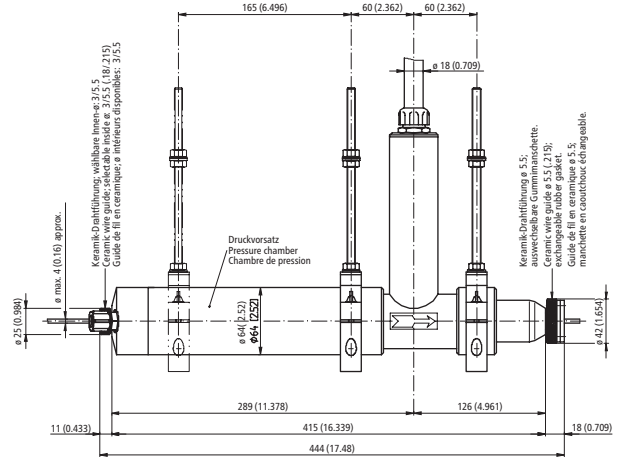

MR.xx.10HS

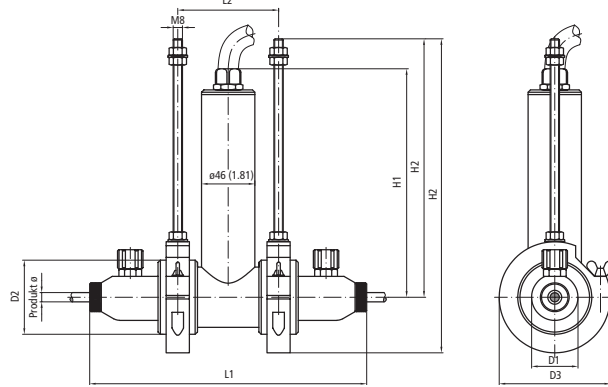

Model	MR 12	MR 36	MR 68
	mm	mm	mm
L1	239	680	1100
L2	~ 87	220...600	295...525
Product ø	8	24	45
D1	40	64	95
D2	64	100	160
D3	96	96	140
H1	197	212	242
H2	223	223	239
H3	271	273	319

CAPAC® HS

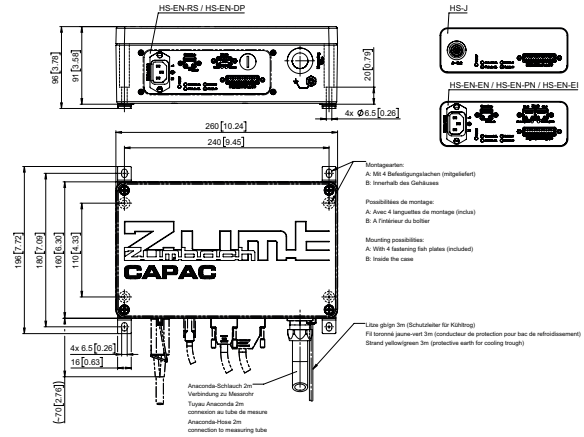

Dimensions in mm (inch)

ACCESSORIES

Special capacitors and tube adapters are available for the calibration of the CAPAC® HS systems. They allow a simple yet effective check of the measuring accuracy.

Calibration capacitors CC1-xx

Measuring tube	Capacitance in the range 0...300 pF/m	Capacitance in the range 0...600 pF/m	Capacitance in the range 0...1800 pF/m
MR.xx.10HS	CC1-3	CC1-3	CC1-56
MR.xx.50HS	CC1-14	CC1-27	CC1-56

Measuring tube adapters MA-MR-xx

Measuring tube	Adapter
MR.12.xx.xx	MA-MR12
MR.36.xx.xx	MA-MR36
MR.68.xx.xx	MA-MR68

Additional accessories: Cleaning sets for measuring tubes, cable guides for different diameters

• Technical specifications are subject to change without notice

WORLDWIDE CUSTOMER SERVICE AND SALES OFFICES



Headquarter:
Zumbach Electronic AG
P.O. Box
CH-2552 Orpund
SWITZERLAND
Tel.: +41 (0)32 356 04 00
sales@zumbach.ch

BENELUX, sales@zumbach.be
CHINA P.R., sales@zumbach.com.cn
CZECH REPUBLIC, jvorlicek@zumbach.cz
FRANCE, ventes@zumbach.com.fr
GERMANY, verkauf@zumbach.de

INDIA, sales@zumbachindia.com
ITALY, zumit@zumbach.it
SPAIN, gestion@zumbach.es
TAIWAN, info@zumbach.tw
UNITED KINGDOM, sales@zumbach.co.uk

North American Headquarter:
Zumbach Electronics Corp.
140 Kisco Avenue
Mount Kisco, NY 10549-1407
Phone +1 914 241 7080
USA
sales@zumbach.com

